

JVC

SERVICE MANUAL

CD RECEIVER

KD-LX330R/KD-LX110R

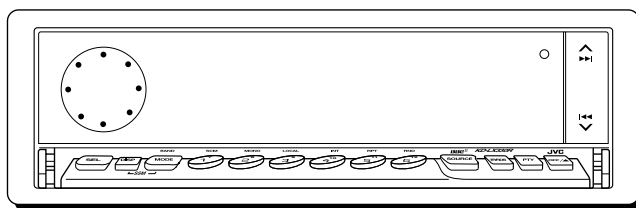
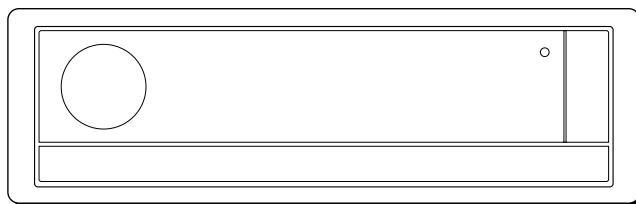
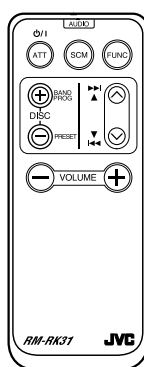

Area Suffix

KD-LX330R

E ----- Continental Europe
EX ----- Central Europe

KD-LX110R

E ----- Continental Europe



Difference point	LINE IN	SUBWOOFER OUT
KD-LX330R	O	O
KD-LX110R	X	X

Contents

Safety precaution	1-2
Preventing static electricity	1-3
Disassembly method	1-4
Adjustment method	1-13
Extension cord connecting method ...	1-14
Functions of the mechanism	
under the service mode	1-16
Flow of functional operation	
until TOC read	1-18
Maintenance of laser pickup	1-20
Replacement of laser pickup	1-20
Description of major ICs	1-21~37

Description of major ICs

■ FAN8037 (IC661) : CD driver

1. Pin layout & Block diagram

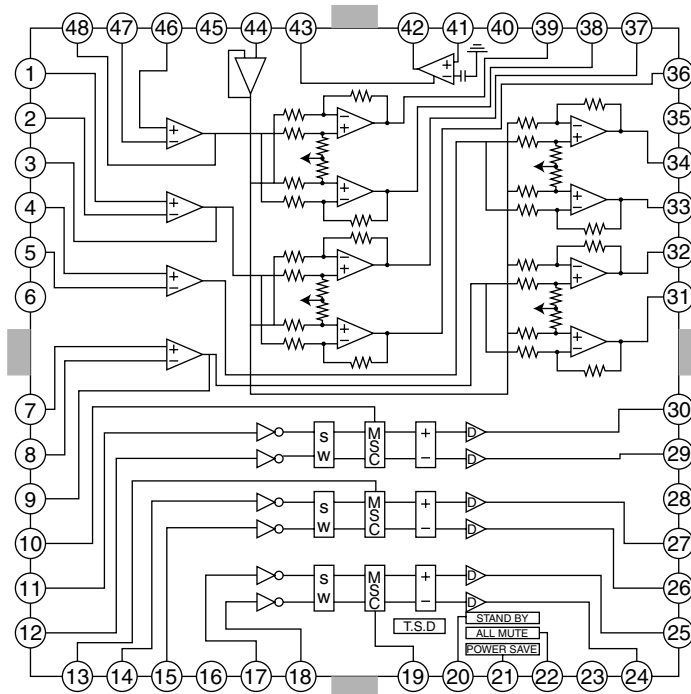

2. Pin function

Pin No.	Symbol	I/O	Function	Pin No.	Symbol	I/O	Function
1	IN2+	I	CH2 op-amp input(+)	25	DO7+	O	CH7 drive output(+)
2	IN2-	I	CH2 op-amp input(-)	26	DO6-	O	CH6 drive output(-)
3	OUT2	O	CH2 op-amp output	27	DO6+	O	CH6 drive output(+)
4	IN3+	I	CH3 op-amp input(+)	28	PGND2	-	Power ground2
5	IN3-	I	CH3 op-amp input(-)	29	DO5-	O	CH5 drive output(-)
6	OUT3	O	CH3 op-amp output	30	DO5+	O	CH5 drive output(+)
7	IN4+	I	CH4 op-amp input(+)	31	DO4-	O	CH4 drive output(-)
8	IN4-	I	CH4 op-amp input(-)	32	DO4+	O	CH4 drive output(+)
9	OUT4	O	CH4 op-amp output(+)	33	DO3-	O	CH3 drive output(-)
10	CTL1	I	CH5 motor speed control	34	DO3+	O	CH3 drive output(+)
11	FWD1	I	CH5 forward input	35	PGND1	-	Power ground1
12	REV1	I	CH5 reverse input	36	DO2-	O	CH2 drive output(-)
13	CTL2	I	CH6 motor speed control	37	DO2+	O	CH2 drive output(+)
14	FWD2	I	CH6 forward input	38	DO1-	O	CH1 drive output(-)
15	REV2	I	CH6 reverse input	39	DO1+	O	CH1 drive output(+)
16	SGND	-	Signal ground	40	PVCC1	-	Power supply voltage
17	FWD3	I	CH7 forward input	41	REGOX	I	Regulator feedback input
18	REV3	I	CH7 reverse input	42	REGX	O	Regulator output
19	CTL3	I	CH7 motor speed control	43	RESX	I	Regulator reset input
20	SB	I	Stand by	44	VREF	I	Bias voltage input
21	PS	I	Power save	45	SVCC	-	Signal supply voltage
22	MUTE	I	All mute	46	IN1+	I	CH1 op-amp input(+)
23	PVCC2	-	Power supply voltage	47	IN1-	I	CH1 op-amp input(-)
24	DO7-	O	CH7 drive output(-)	48	OUT1	O	CH1 op-amp output

■ UPD784215AGC-128 (IC701) : UNIT CPU

1. Terminal Layout

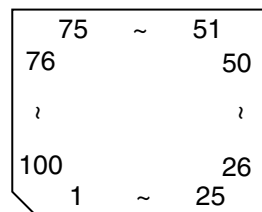

2. Pin Function (1/2)

Pin No.	Symbol	I/O	Function
1	SW2	I	Detection switch of CD mechanism
2	SW3	I	Detection switch of CD mechanism
3	SW4	I	Detection switch of CD mechanism
4	REST-SW	I	Reset signal input from CD mechanism
5	LM0	O	Loading motor control signal output
6	LM1	O	Loading motor control signal output
7	DIMMER-OUT	O	Dimmer signal output
8	LCD-PWR	O	LCD driver power supply control output H:ON
9	VDD	-	Power supply terminal
10	X2	-	Connecting the crystal oscillator for system main clock
11	X1	-	Connecting the crystal oscillator for system main clock
12	VSS	-	Power supply terminal
13	XT2	-	Connecting the crystal oscillator for system sub clock
14	XT1	-	Connecting the crystal oscillator for system sub clock
15	RESET	I	System reset signal input
16	SW1	I	Detection switch of CD mechanism
17	BUS-INT	I	Cut-in input for J-BUS signal
18	PS2	I	Power save 2, Working together back up by H input, to stop mode
19	CRUISE	I	Pulse signal input port for Cruise control
20	NC	-	Clock signal input for RDS
21	NC	-	RDS data input
22	REMOCON	I	Remote control signal input
23	AVDD	-	Power supply terminal
24	AVREF0	-	Power supply terminal
25	VOL1	I	Input for rotation volume detection pulse judgment to relation V1
26	VOL2	I	Input for rotation volume detection pulse judgment to relation V2
27	KEY0	I	Key control signal input 0
28	KEY1	I	Key control signal input 1
29	KEY2	I	Key control signal input 2
30	LEVEL	I	Signal input port of level meter
31	NC	I	Non connect
32	S.METER	I	S.Meter level input
33	AVSS	-	Connect to GND
34	W-VOL	O	Subwoofer volume control analogue output
35	DOT-CONT	O	Dot contrast signal output
36	AVREF	-	Power supply terminal
37	BUS-SI	I	J-BUS data input
38	BUS-SO	O	J-BUS data output
39	BUS-SCK	I/O	J-BUS Clock signal I/O
40	STAGE2	I	Initial setting
41	LCD-DA	O	Data output to LCD driver
42	LCDCL	O	Clock output to LCD driver

Pin Function (2/2)

Pin No.	Symbol	I/O	Function
43	LCD-CE1	O	Chip enable output to LCD driver
44	BUZZER	O	BUZZER control signal output
45	E2PR-DA-I	I	Data input terminal from EEPROM
46	E2PR-DA-O	O	Data output terminal for EEPROM
47	E2PR-CLK	O	Clock signal I/O terminal with EEPROM
48	BUS-I/O	I/O	J-BUS I/O signal terminal
49	TM0	O	Tray motor negative signal output terminal
50	TM1	O	Tray motor positive signal output terminal
51	DM0	O	Door motor negative signal output terminal
52	DM1	O	Door motor positive signal output terminal
53	SD/ST	I	Station detector, Stereo signal input, H:Find Station L:Stereo
54	LOCAL	O	Local ON/OFF select signal output terminal
55	MONO	O	Monaural ON/OFF selecting output, H:MONO ON
56~60	CA-SW1~5	I	DOOR/TRAY open close detect switch signal input terminal
61,62	NC	-	Non connect
63	SEEK/STOP	O	Auto seek/stop selecting output, H:Seek L:Stop
64	NC	-	Non connect
65	FM/AM	O	Selecting output for FM/AM, L:FM H:AM
66	PLL-CE	O	CE output for IC control for PLL
67	PLL-DA	O	Data output for IC control for PLL
68	PLL-CK	O	Clock output for IC control for PLL
69	BAND IN	I	AM detect signal input
70	NC	-	Non connect
71	AMP KILL	-	Non connect
72	VSS	-	Connect to GND
73	DIMMER-IN	I	DIMMER signal input terminal
74	PS1	I	Power supply terminal
75	POWER	O	Selecting output for power ON/OFF, H:power ON
76	CD-ON	O	Power supply control signal for CD H:CD
77	MUTE	O	MUTE output, L:MUTE ON
78	W-LPF1	O	Subwoofer cut off frequency output 1
79	W-LPF2	O	Subwoofer cut off frequency output 2
80	W-MUTE	O	MUTE output for Subwoofer
81	VDD	-	Power supply terminal
82	VO-DA	O	Data output terminal
83	VOL-CLK	O	Clock signal output terminal
84	NC	-	Non connect
85	GVSW	O	AGC/FE/TE amp gain change terminal
86	LCDRST	O	LCD reset signal output terminal
87	LCD-CE2	O	Chip enable 2 output terminal for LCD driver
88	DMK	O	Motor speed control signal output terminal
89	TMK	O	Tray motor control signal output terminal
90	NC	-	Non connect
91	BUCK	O	Micon interface clock output terminal
92	CCE	O	Command and data sending/receiving chip enable signal output
93	RST	O	Reset signal output terminal reset at "L" level
94	TEST	-	Connect to GND
95~98	BUS0~3	I/O	Micon interface data input/output terminal
99	DISC SEL	I	Initial setting
100	NC	-	Non connect

■TC9490FA (IC521) : DSP

1. Pin layout & Block diagram

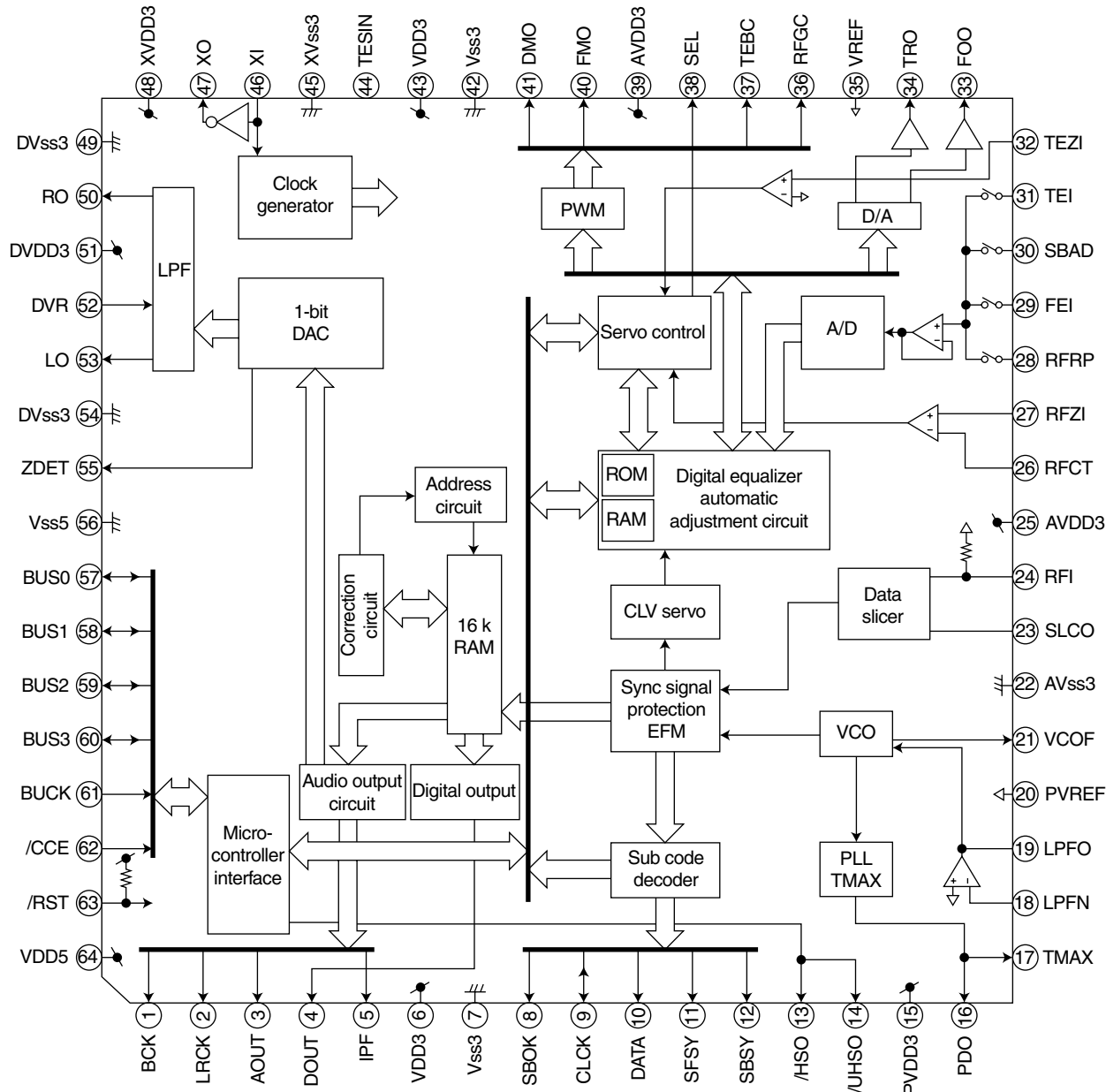

2. Pin function (1/2)

Pin No.	Symbol	I/O	Function
1	BCK	O	Bit clock output terminal
2	LRCK	O	L/R channel clock output terminal
3	AOUT	O	Audio data output terminal
4	DOUT	O	Digital data output terminal
5	IPF	O	Correction flag output terminal
6	VDD3	-	Digital 3.3V power supply voltage terminal
7	Vss3	-	Digital GND terminal
8	SBOK	O	Subcode Q data CRCC result output terminal
9	CLCK	O	Subcode P-W data read clock I/O terminal
10	DATA	O	Subcode P-W data output terminal
11	SFSY	O	Playback frame sync signal output terminal
12	SBSY	O	Subcode block sync signal output terminal
13	/HSO	O	Playback speed mode output terminal

2. Pin function (2/2)

Pin No.	Symbol	I/O	Function
14	/UHSO	O	Playback speed mode output terminal
15	PVDD3	-	PLL-only 3.3V power supply voltage terminal
16	PDO	O	EFM and PLCK phase difference signal output terminal
17	TMAX	O	TMAX detection result output terminal
18	LPFN	I	Inverted input terminal for PLL LPF amp
19	LPFO	O	Output terminal for PLL LPF amp
20	PVREF	-	PLL-only VREF terminal
21	VCOF	O	VCO filter terminal
22	AVss3	-	Analog GND terminal
23	SLCO	O	DAC output terminal for data slice level generation
24	RFI	I	RF signal input terminal
25	AVDD3	-	Analog 3.3V power supply voltage terminal
26	RFCT	I	RFRP signal center level input terminal
27	RFZI	I	RFRP signal zero-cross input terminal
28	RFRP	I	RF ripple signal input terminal
29	FEI	I	Focus error signal input terminal
30	SBAD	I	Sub-beam adder signal input terminal
31	TEI	I	Tracking error input terminal
32	TEZI	I	Tracking error signal zero-cross input terminal
33	FOO	O	Focus equalizer output terminal
34	TRO	O	Tracking equalizer output terminal
35	VREF	-	Analog reference power supply voltage terminal
36	RFGC	O	RF amplitude adjustment control signal output terminal
37	TEBC	O	Tracking balance control signal output terminal
38	SEL	O	APC circuit ON/OFF signal output terminal
39	AVDD3	-	Analog 3.3V power supply voltage terminal
40	FMO	O	Feed equalizer output terminal
41	DMO	O	Disc equalizer output terminal
42	Vss3	-	Digital GND terminal
43	VDD3	-	Digital 3.3V power supply voltage terminal
44	TESIN	I	Test input terminal
45	XVss3	-	System clock oscillator GND terminal
46	XI	I	System clock oscillator input terminal
47	XO	O	System clock oscillator output terminal
48	XVDD3	-	System clock oscillator 3.3V power supply voltage terminal
49	DVss3	-	DA converter GND terminal
50	RO	O	R-channel data forward output terminal
51	DVDD3	-	DA converter 3.3V power supply terminal
52	DVR	-	Reference voltage terminal
53	LO	O	L-channel data forward output terminal
54	DVss3	-	DA converter GND terminal
55	ZDET	O	1 bit DA converter zero data detection flag output terminal
56	Vss5	-	Microcontroller interface GND terminal
57	BUS0	I/O	Microcontroller interface data I/O terminal
58	BUS1	I/O	Microcontroller interface data I/O terminal
59	BUS2	I/O	Microcontroller interface data I/O terminal
60	BUS3	I/O	Microcontroller interface data I/O terminal
61	BUCK	I	Microcontroller interface clock input terminal
62	/CCE	I	Microcontroller interface chip enable signal input terminal
63	/RST	I	Reset signal input terminal
64	VDD5	-	Microcontroller interface 5V power supply terminal

■ 000874360-T (IC702) : System reset

1. Pin layout

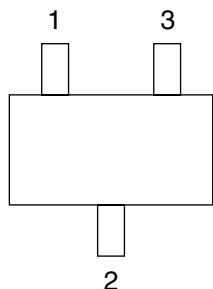

2. Block diagram

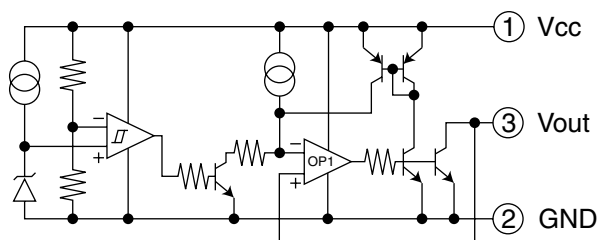

■ BA3220FV-X (IC301,IC401) : Driver

1. Pin layout & Block diagram

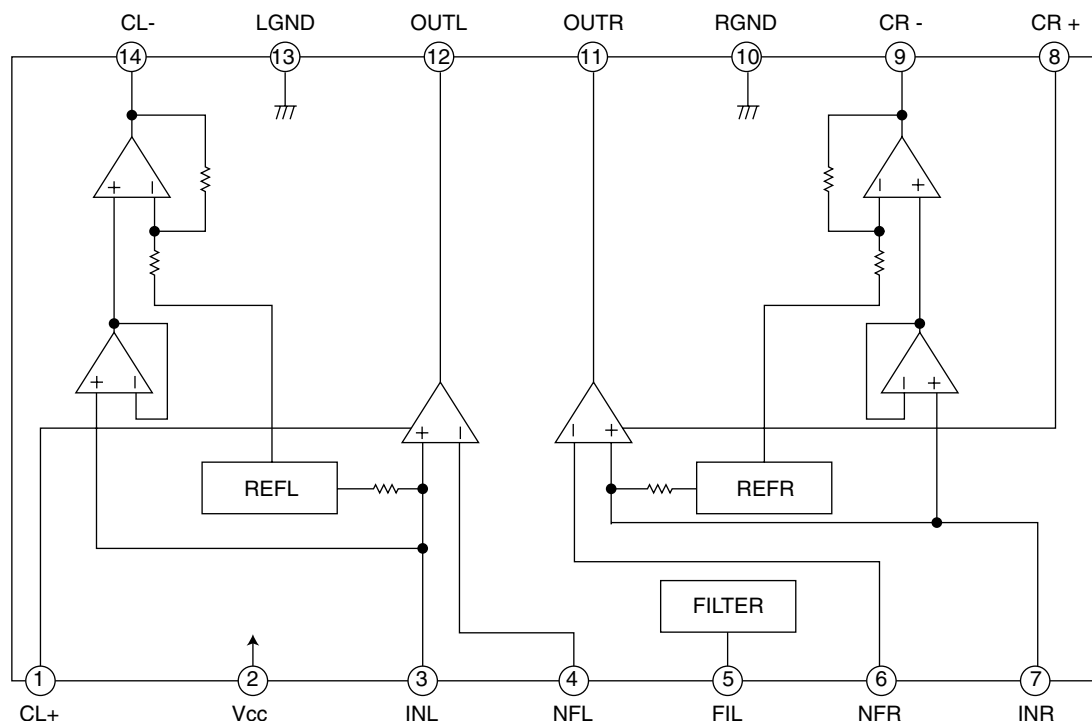

2. Pin function

Pin No.	Symbol	Function
1	CL+	Power supply terminal for amp.
2	Vcc	power supply terminal.
3	INL	input terminal.
4	NFL	Negative feedback terminal.
5	FIL	Filter terminal.
6	NFR	Negative feedback terminal.
7	INR	Input terminal
8	CR+	Power supply terminal for amp.
9	CR-	Output terminal of internal amp.
10	RGND	Rch GND terminal.
11	OUTR	Rch output terminal.
12	OUTL	Lch output terminal.
13	LGND	Lch GND terminal.
14	CL-	Output terminal of internal amp.

■ **BD3860K (IC911) : E. volume**

1. Terminal layout

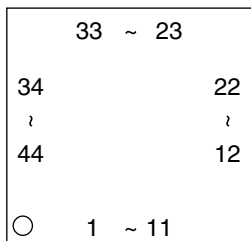

2. Block diagram

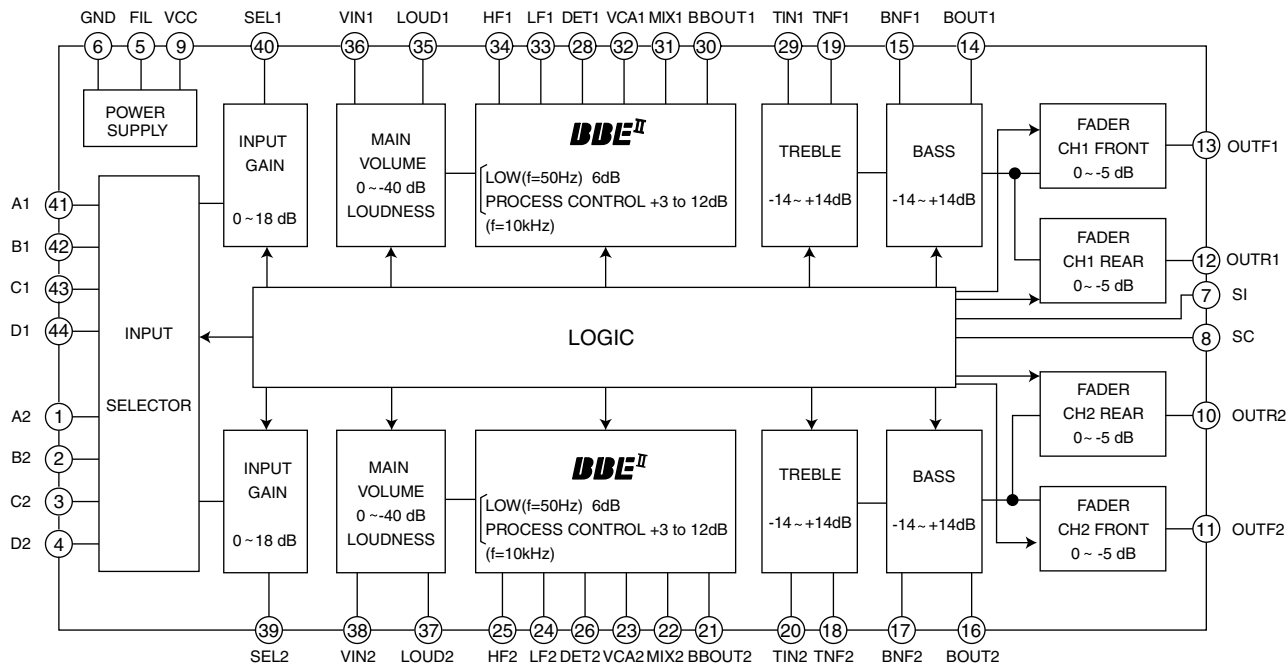

3. Pin function

Pin No.	Symbol	Function	Pin No.	Symbol	Function
1	A2	CH2 Input Pin A	23	VCA2	CH2 High Pass VCA Output Pin
2	B2	CH2 Input Pin B	24	LF2	CH2 Low Pass Filter Setting Pin
3	C2	CH2 Input Pin C	25	HF2	CH2 High Pass Filter Setting Pin
4	D2	CH2 Input Pin D	26	DET2	CH2 High Pass Attack/Release Time Setting Pin
5	FIL	1/2 VCC Pin	27	NC	Non connect
6	GND	Ground Pin	28	DET1	CH1 High Pass Attack/Release Time Setting Pin
7	SI	Serial Data Receiving Pin	29	TIN1	CH1 treble Input Pin
8	SC	Serial Clock Receiving Pin	30	BBOUT1	CH1 BBE II Signal Output Pin
9	VCC	Power Supply Pin	31	MIX1	CH1 Output MIX Amplifier Inverse Input Pin
10	OUTR2	CH2 Rear Output Pin	32	VCA1	CH1 High Pass VCA Output Pin
11	OUTF2	CH2 Front Output Pin	33	LF1	CH1 Low Pass Filter Setting Pin
12	OUTR1	CH1 Rear Output Pin	34	HF1	CH1 High Pass Filter Setting Pin
13	OUTF1	CH1 Front Output Pin	35	LOUD1	CH1 Loudness Filter Setting Pin
14	BOUT1	CH1 Bass Filter Setting Pin	36	VIN1	CH1 Main Volume Input Pin
15	BNF1	CH1 Bass Filter Setting Pin	37	LOUD2	VCH2 Loudness Filter setting Pin
16	BOUT2	CH2 Bass Filter Setting Pin	38	VIN2	CH2 Main Volume Input Pin
17	BNF2	CH2 Bass Filter Setting Pin	39	SEL2	CH2 Input Gain Output Pin
18	TNF2	CH2 treble Filter Setting Pin	40	SEL1	CH1 Input Gain output Pin
19	TNF1	CH1 treble Filter Setting Pin	41	A1	CH1 Input Pin A
20	TIN2	CH2 treble Input Pin	42	B1	CH1 Input Pin B
21	BBOUT2	CH2 BBE II Signal Output Pin	43	C1	CH1 Input Pin C
22	MIX2	CH2 Output MIX Amplifier Inverse Input Pin	44	D1	CH1 Input Pin D

■ **BR24C16F-X (IC703) : EEPROM**

1. Pin layout

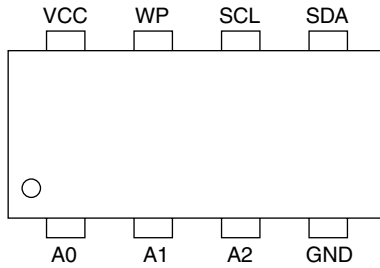

2. Pin function

Symbol	I/O	Function
VCC	-	Power supply.
GND	-	GND
A0,A1,A2	I	No use connect to GND.
SCL	I	Serial clock input.
SDA	I/O	Serial data I/O of slave and ward address.
WP	I	Write protect terminal.

3. Block diagram

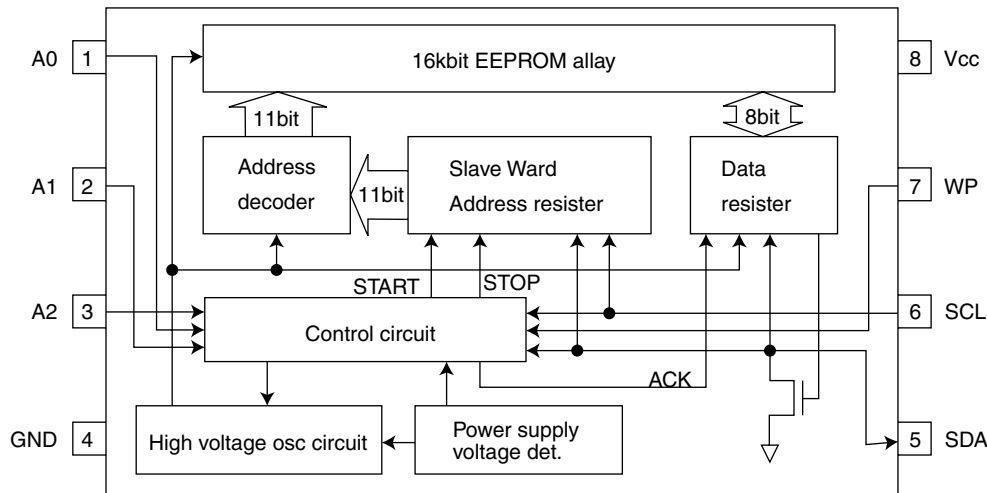

■ **BU4066BCFV-X (IC322) : Quad analog switch**

1. Pin layout & Block diagram

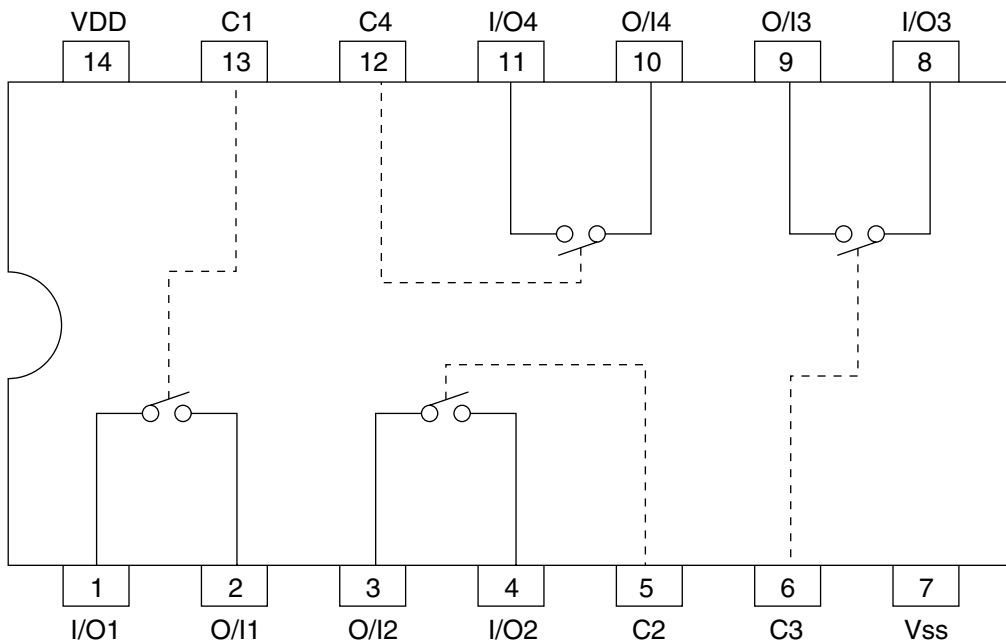

HA13164 (IC961) : Regulator

1. Terminal layout



2. Block diagram

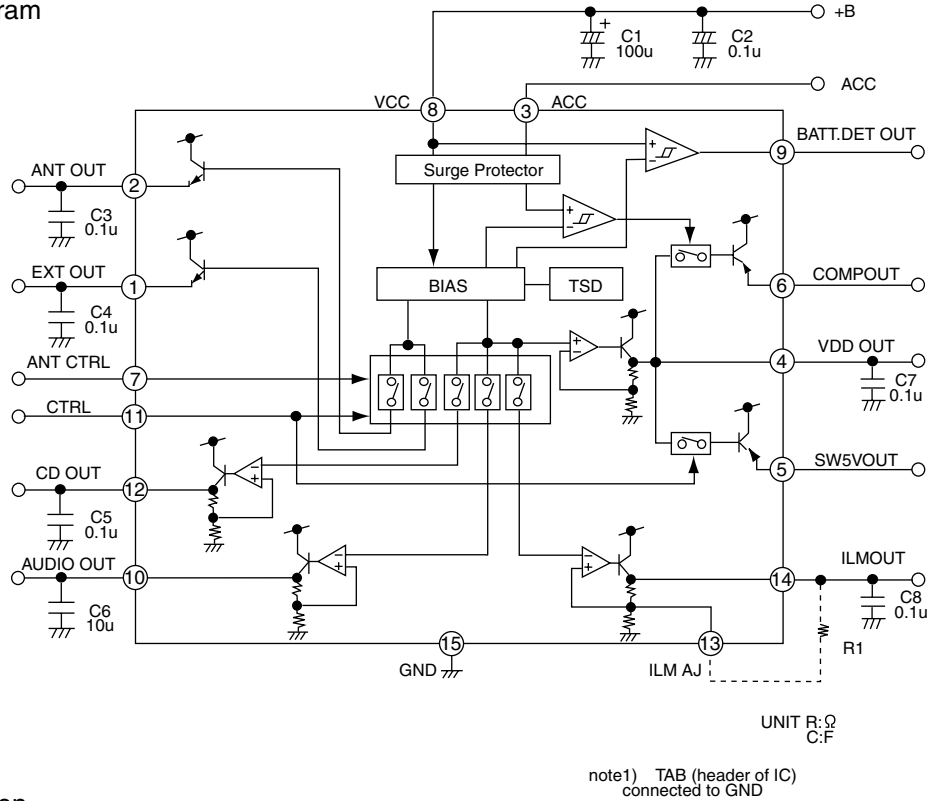

3. Pin function

Pin No.	Symbol	Function
1	EXTOUT	Output voltage is VCC-1 V when M or H level applied to CTRL pin.
2	ANTOUT	Output voltage is VCC-1 V when M or H level to CTRL pin and H level to ANT-CTRL.
3	ACCIN	Connected to ACC.
4	VDDOUT	Regular 5.7V.
5	SW5VOUT	Output voltage is 5V when M or H level applies to CTRL pin.
6	COMPOUT	Output for ACC detector.
7	ANT CTRL	L:ANT output OFF , H:ANT output ON
8	VCC	Connected to VCC.
9	BATT DET	Low battery detect.
10	AUDIO OUT	Output voltage is 9V when M or H level applied to CTRL pin.
11	CTRL	L:BIAS OFF, M:BIAS ON, H:CD ON
12	CD OUT	Output voltage is 8V when H level applied to CTRL pin.
13	ILM AJ	Adjustment pin for ILM output voltage.
14	ILM OUT	Output voltage is 10V when M or H level applies to CTRL pin.
15	GND	Connected to GND.

■ LA4743K (IC941) : Power amp

1. Block diagram

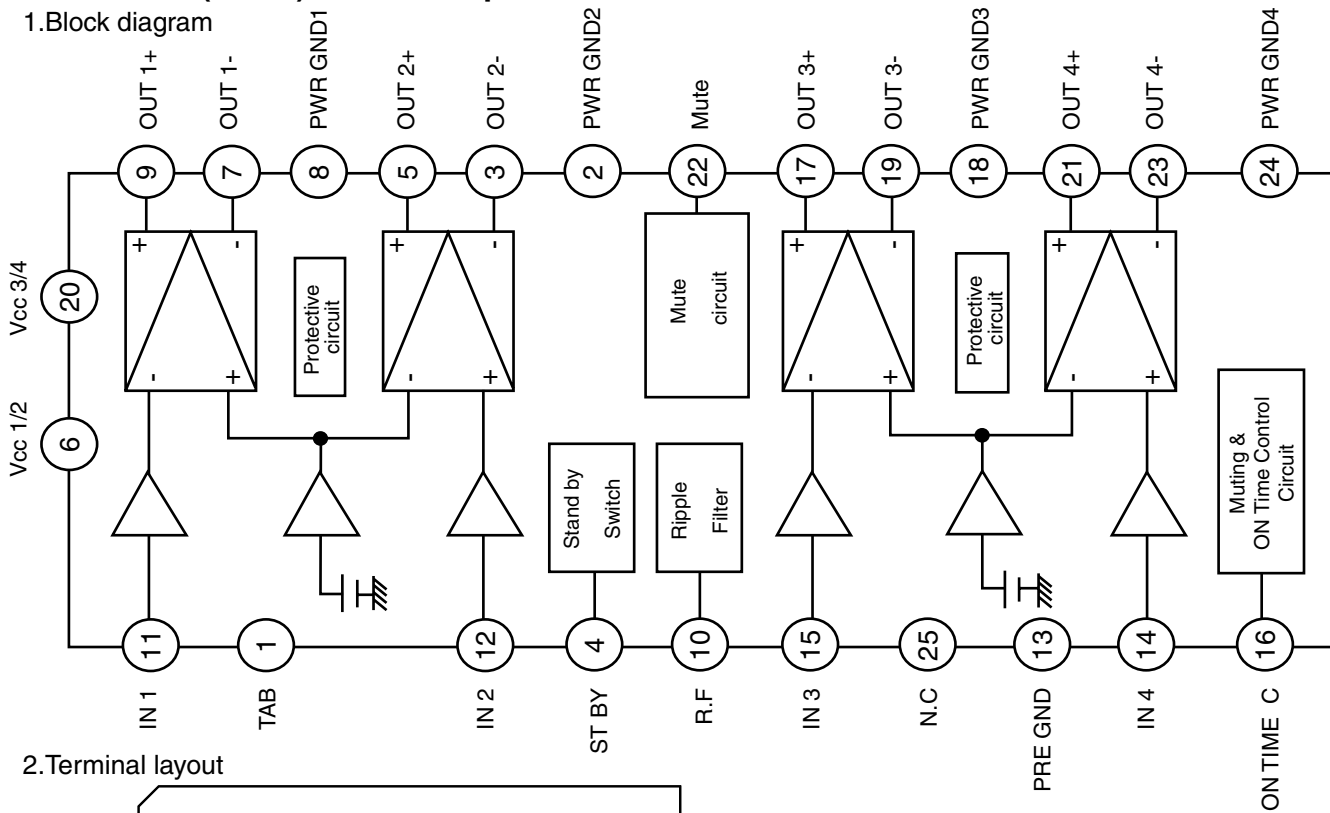

2. Terminal layout

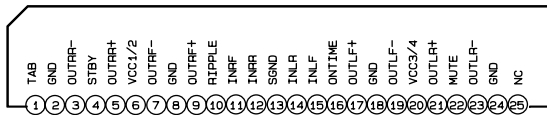

3. Pin function

Pin No.	Symbol	Function
1	TAB	Header of IC
2	GND	Power GND
3	OUTRR-	Output(-) for front Rch
4	STBY	Stand by input
5	OUTRR+	Output (+) for front Rch
6	VCC1/2	Power input
7	OUTRF-	Output (-) for rear Rch
8	GND	Power GND
9	OUTRF+	Output (+) for rear Rch
10	RIPPLE	Ripple filter
11	INRF	Rear Rch input
12	INRR	Front Rch input
13	SGND	Signal GND
14	INLR	Front Lch input
15	INLF	Rear Lch input
16	ONTIME	Power on time control
17	OUTLF+	Output (+) for rear Lch
18	GND	Power GND
19	OUTLF-	Output (-) for rear Lch
20	VCC3/4	Power input
21	OUTLR+	Output (+) for front
22	MUTE	Muting control input
23	OUTLR-	Output (-) for front
24	GND	Power GND
25	NC	Non connection

■ LC75811W (IC602) : LCD driver

1. Pin layout

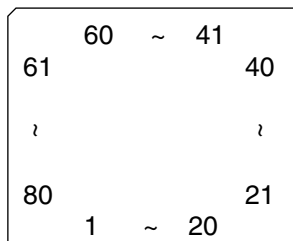

2. Block diagram

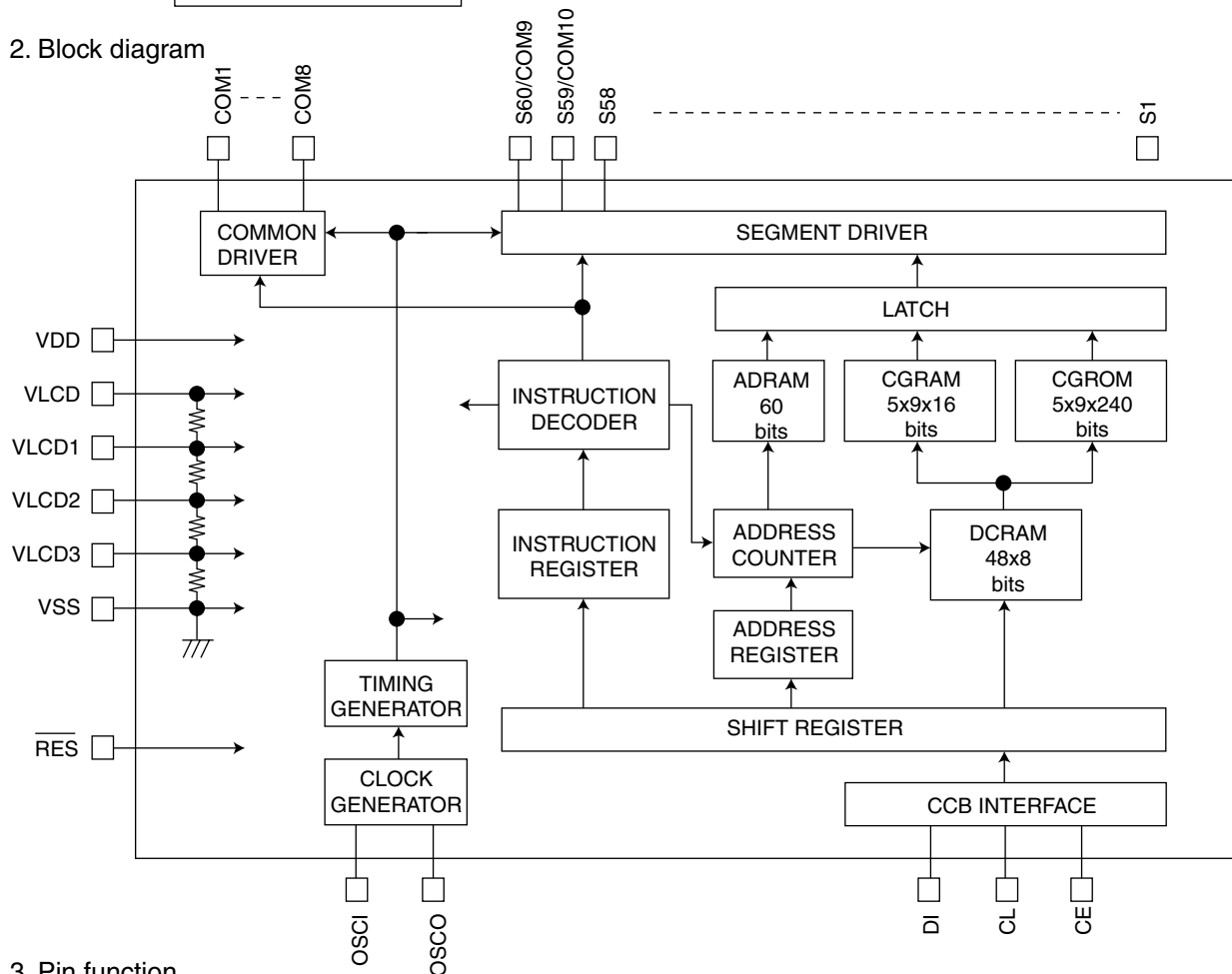

3. Pin function

Pin No.	Symbol	I/O	Function
1~58	S3~S60	O	Segment driver output terminal
59	COM0	O	Common driver output terminal
60~65	COM3~COM8	O	Common driver output terminal
66	COM1	O	Common driver output terminal
67	VDD	-	Power supply for logic section
68	VLCD	-	Power supply for LCD driver section
69~71	VLCD1~VLCD3	I	LCD voltage input terminal
72	VSS	-	Connect to ground
73	OSCO	O	Oscillation output terminal
74	OSCI	I	Oscillation input terminal
75	RES	I	Reset signal input terminal
76	CE	I	Chip enable input terminal
77	CL	I	Clock signal input terminal
78	DI	I	Serial data input terminal
79~80	S1~S2	O	Segment driver output terminal

■ **LC75823W (IC602) : LCD driver**

1. Pin Layout & Symbol

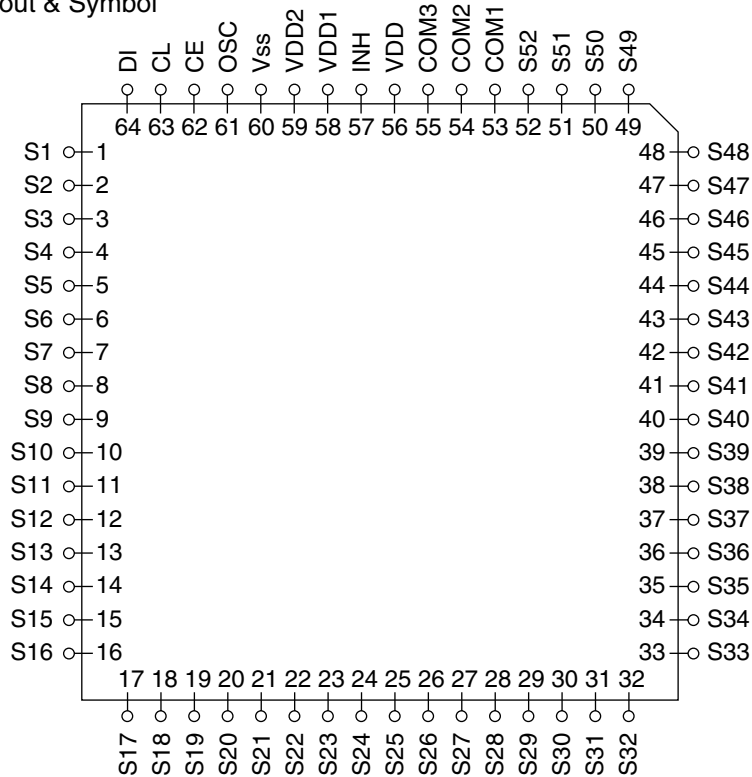

2. Pin Function

Pin No.	Symbol	I/O	Function
1 to 52	S1 to S52	O	Segment output pins used to display data transferred by serial data input.
53 to 55	COM1 to COM3	O	Common driver output pins. The frame frequency is given by : $t_0 = (f_{osc}/384)Hz$.
56	VDD	--	Power supply connection. Provide a voltage of between 4.5 and 6.0V.
57	\overline{INH}	I	Display turning off input pin. $\overline{INH} = "L"$ (Vss) ----- off (S1 to S52, COM1 to COM3="L") $\overline{INH} = "H"$ (VDD)----- on Serial data can be transferred in display off mode.
58	VDD1	I	Used for applying the LCD drive 2/3 bias voltage externally. Must be connected to VDD2 when a 1/2 bias drive scheme is used.
59	VDD2	I	Used for applying the LCD drive 1/3 bias voltage externally. Must be connected to VDD1 when a 1/2 bias drive scheme is used.
60	Vss	--	Power supply connection. Connect to GND.
61	OSC	I/O	Oscillator connection. An oscillator circuit is formed by connecting an external resistor and capacitor at this pin.
62	CE		Serial data interface connection to the controller. CE : Chip enable
63	CL	I	CL : Sync clock
64	DI		DI : Transfer data

■ NJM2904M (IC951) : Dual ope amp

1. Pin layout

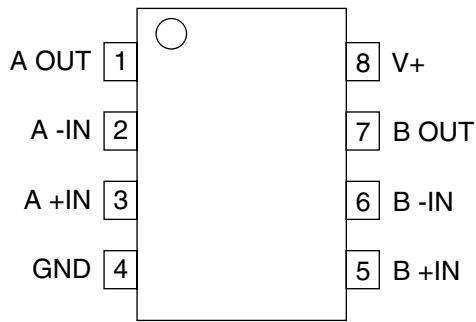

■ NJM4565MD (IC323,IC960) : Ope amp

1. Pin layout & Block diagram

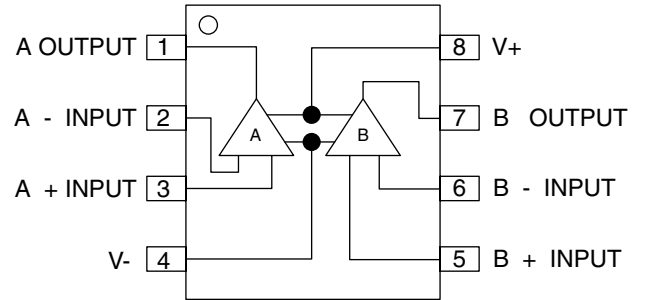

■ RPM6938-SV4 (IC603) : Remote censor

1. Block diagram

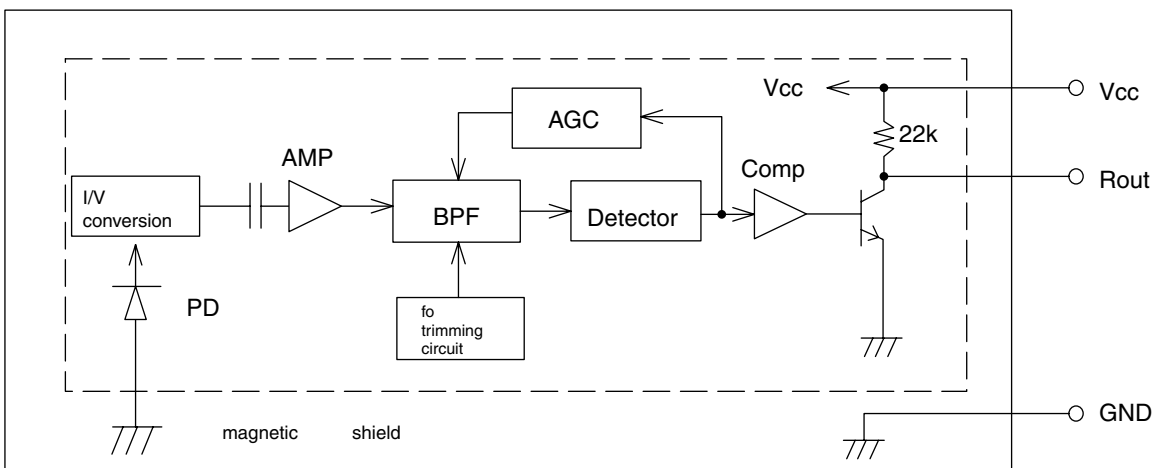

■ M5282FP-XE (IC321) : E. volume

1. Pin layout

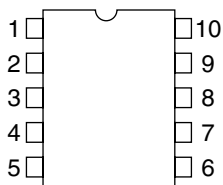

2. Block diagram

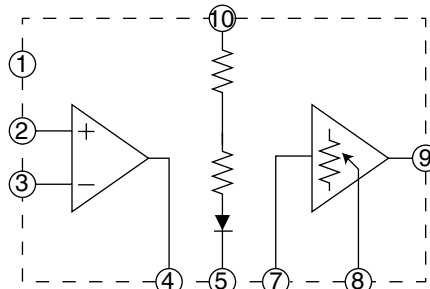

3. Pin function

Pin No.	Symbol	Function
1	Vcc/2	Vcc/2 output for microphone amp.
2	Amp+IN	Microphone amp. positive input terminal.
3	Amp-IN	Microphone amp. negative input terminal.
4	Amp OUT	Microphone amp. output terminal.
5	GND	Ground.
6	NC	Non connection.
7	VCA IN	VCA input terminal.
8	Vc	VCA control terminal.
9	VCA OUT	VCA output terminal.
10	Vcc	Power supply.

■ TA2147F-X (IC601) : Head amp

1. Pin layout & Block diagram

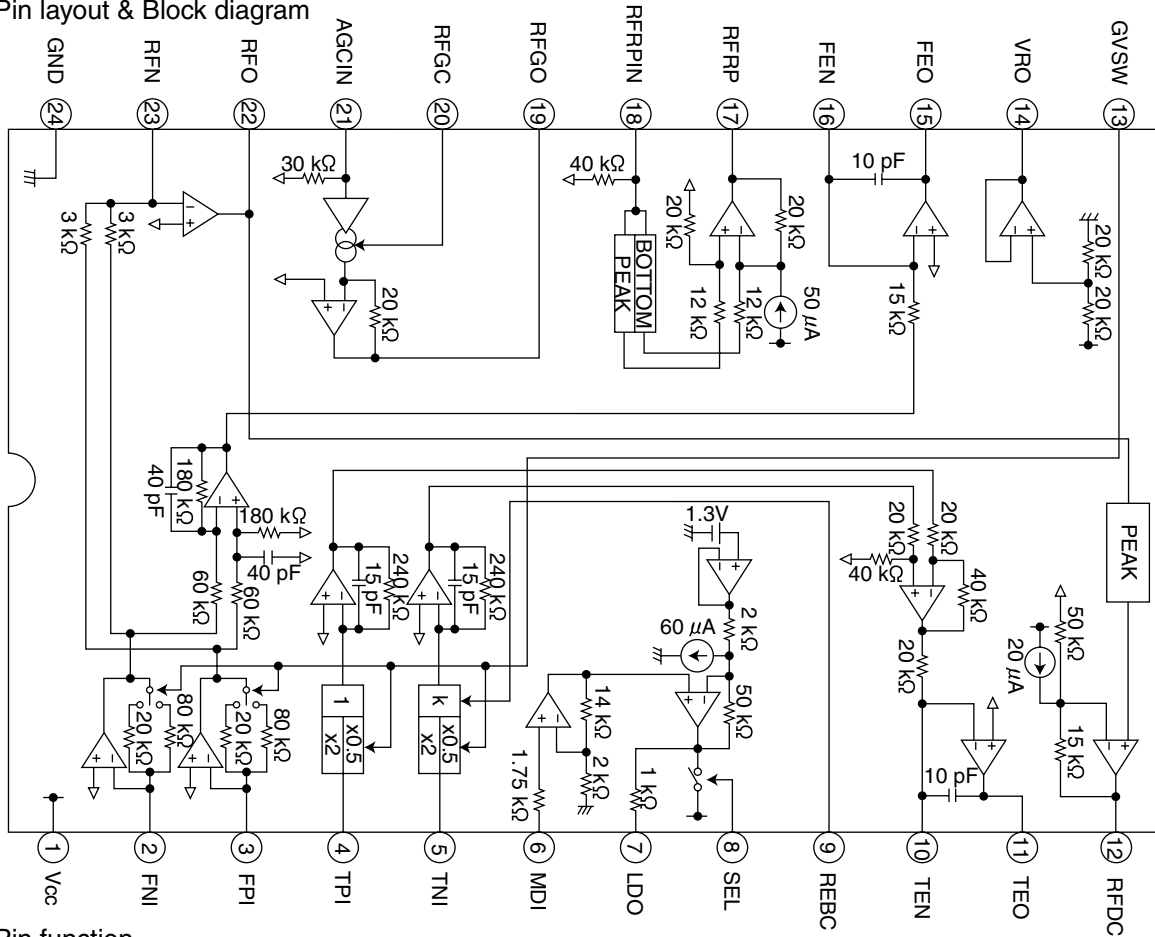

2. Pin function

Pin No.	Symbol	I/O	Function
1	Vcc	-	3.3V power supply terminal
2	FIN	I	Main-beam amp input terminal
3	FPI	I	Main-beam amp input terminal
4	TPI	I	Sub-beam amp input terminal
5	TNI	I	Sub-beam amp input terminal
6	MDI	I	Monitor photo diode amp input terminal
7	LDO	O	Laser diode amp output terminal
8	SEL	I	APC circuit ON/OFF control signal, laser diode (LDO) control signal input or bottom/peak detection frequency change terminal
9	TEBC	I	Tracking error balance adjustment signal input terminal
10	TEN	I	Tracking error signal generation amp negative-phase input terminal
11	TEO	O	Tracking error signal generation amp output terminal
12	RFDC	O	RF signal peak detection output terminal
13	GVSW	I	AGC/FE/TE amp gain change terminal
14	VRO	O	Reference voltage (VRO) output terminal
15	FEO	O	Focus error signal generation amp output terminal
16	FEN	I	Focus error signal generation amp negative-phase input terminal
17	RFRP	O	Signal amp output pin for track count
18	RFRPIN	I	Signal generation amp input terminal for track count
19	RFGO	O	RF signal amplitude adjustment amp output terminal
20	RFGC	I	RF amplitude adjustment control signal input terminal
21	AGCIN	I	RF signal amplitude adjustment amp input terminal
22	RFO	O	RF signal generation amp output terminal
23	RFN	I	RF signal generation amp input terminal
24	GND	-	GND terminal

■ TA8273H (IC941) : 4ch amp

1. Pin layout

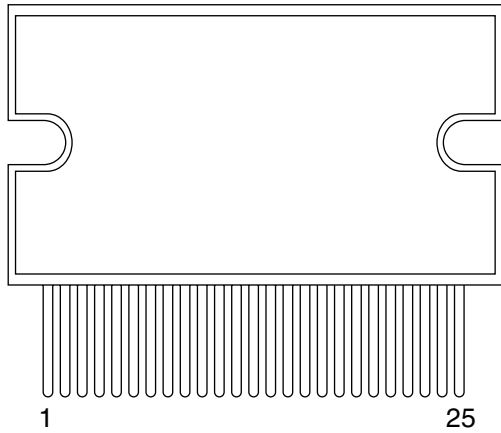

2. Block diagram

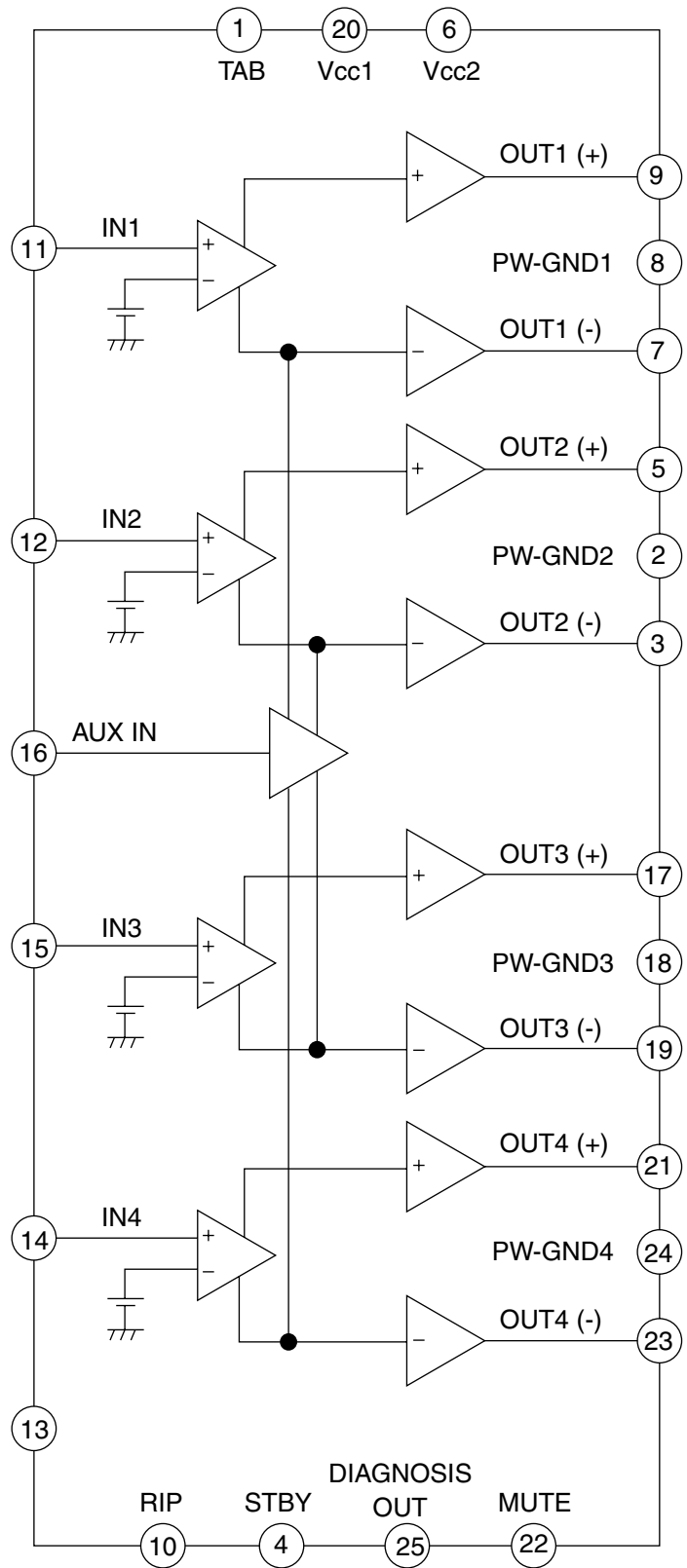

■TB2118F-X (IC21) : PLL

1. Terminal Layout

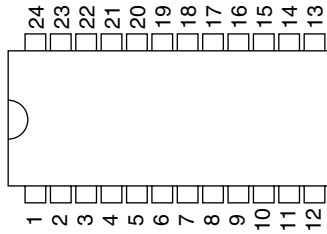

2. Block diagram

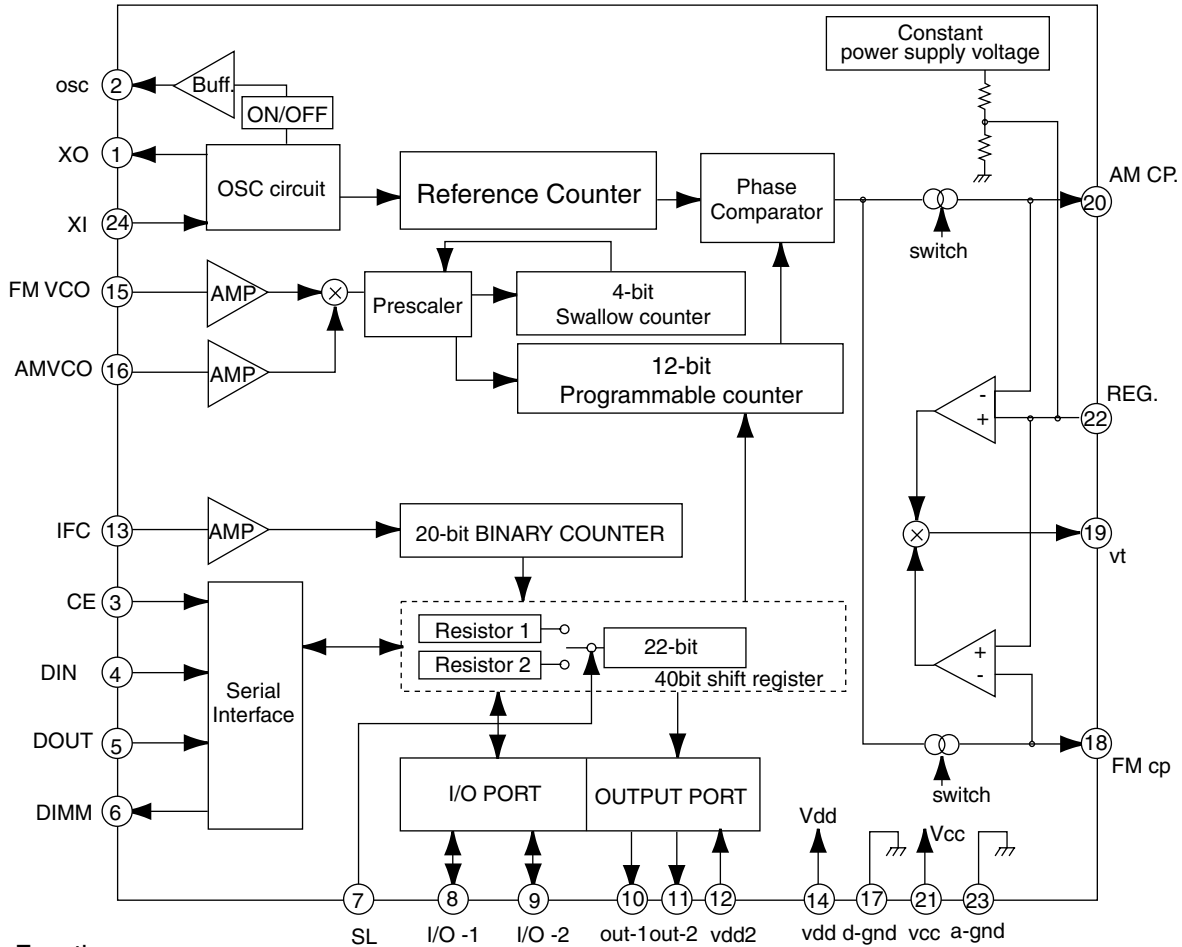

3. Pin Function

Pin No.	Symbol	I/O	Function	Pin No.	Symbol	I/O	Function
1	XOUT	O	Crystal oscillator pin	13	IFC	I	IF signal input
2	OSC	-	Non connect	14	VDD	-	Power pins for digital block
3	CE	I	Chip enable input	15	FMIN	I	FM band local signal input
4	DI	I	Serial data input	16	AMIN	I	AM band local signal input
5	CK	I	Clock input	17	DGND	-	Connect to GND (for digital circuit)
6	DOUT	O	Serial data output	18	FMCP	O	Charge pump output for FM
7	SR	O	Register control pin	19	VT	-	Tuning voltage biased to 2.5V.
8	I/O1	I/O	I/O ports	20	AMCP	O	Charge pump output for AM
9	I/O2	I/O	I/O ports	21	VCC	-	Power pins for analog block
10	OUT1	-	Non connect	22	RF	I	Ripple filter connecting pin
11	OUT2	-	Non connect	23	AGND	-	Connect to GND (for analog circuit)
12	VDD2	-	Single power supply for REF. frequency block	24	XIN	I	Crystal oscillator pin

■ HD74HC126FP (IC771) : Changer control

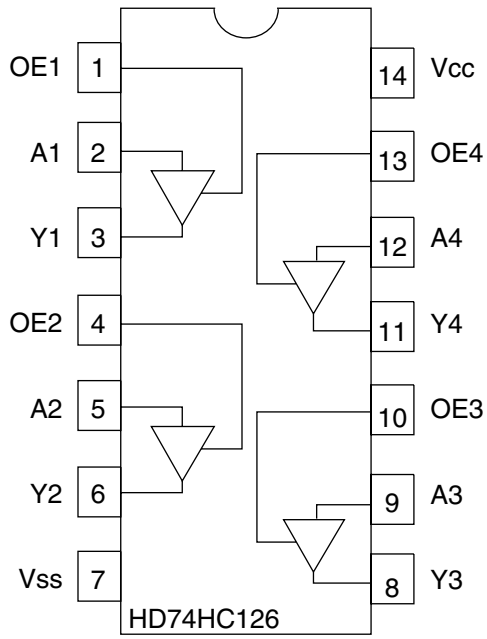

■ NJM2100M (IC821) : Operation amp

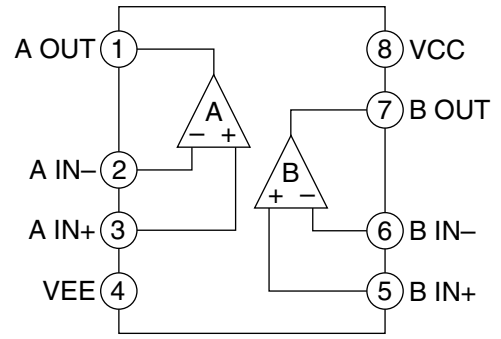

Block diagram

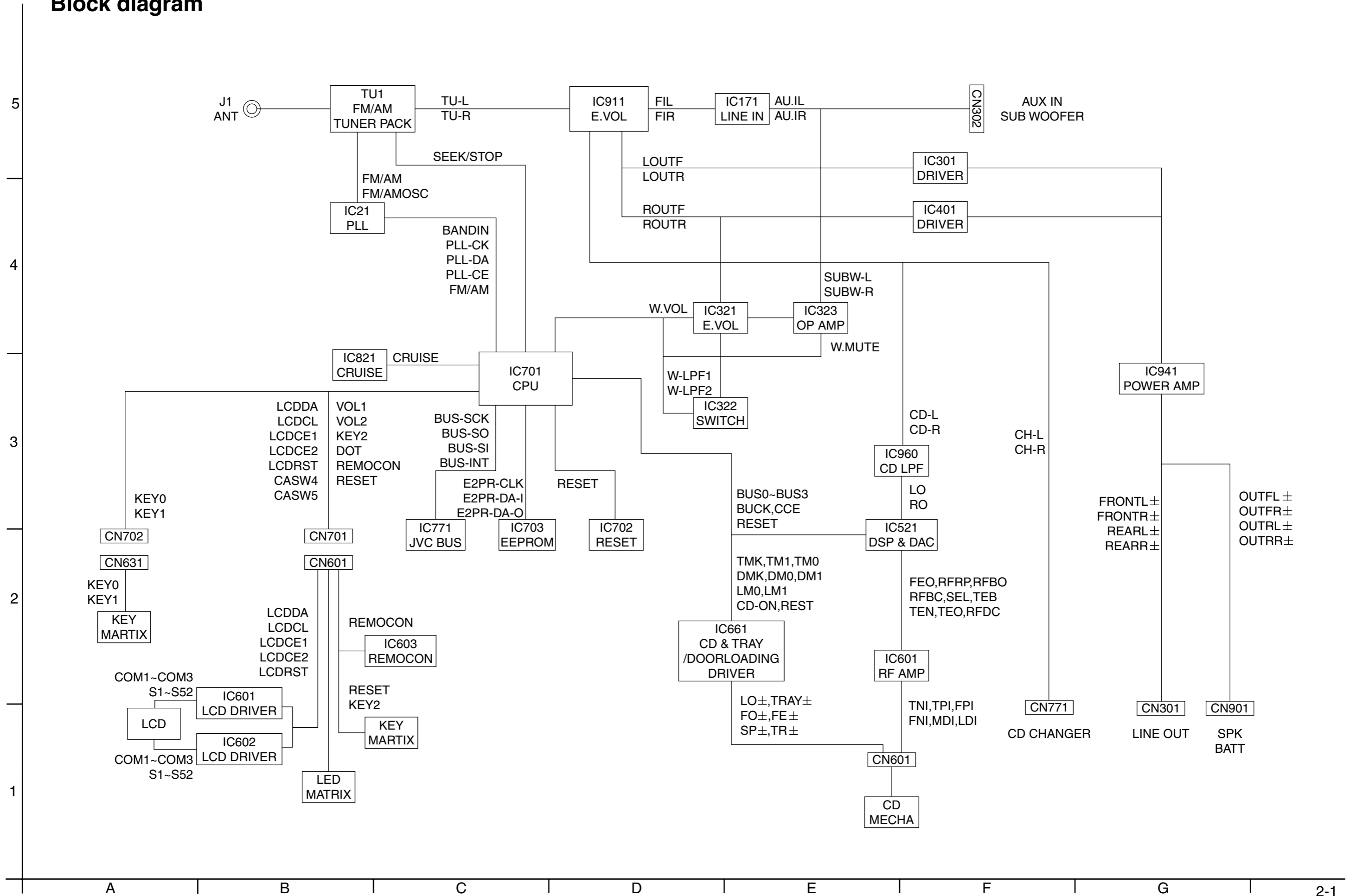

Standard schematic diagrams ■ KD-LX330R

5

4

3

2

1

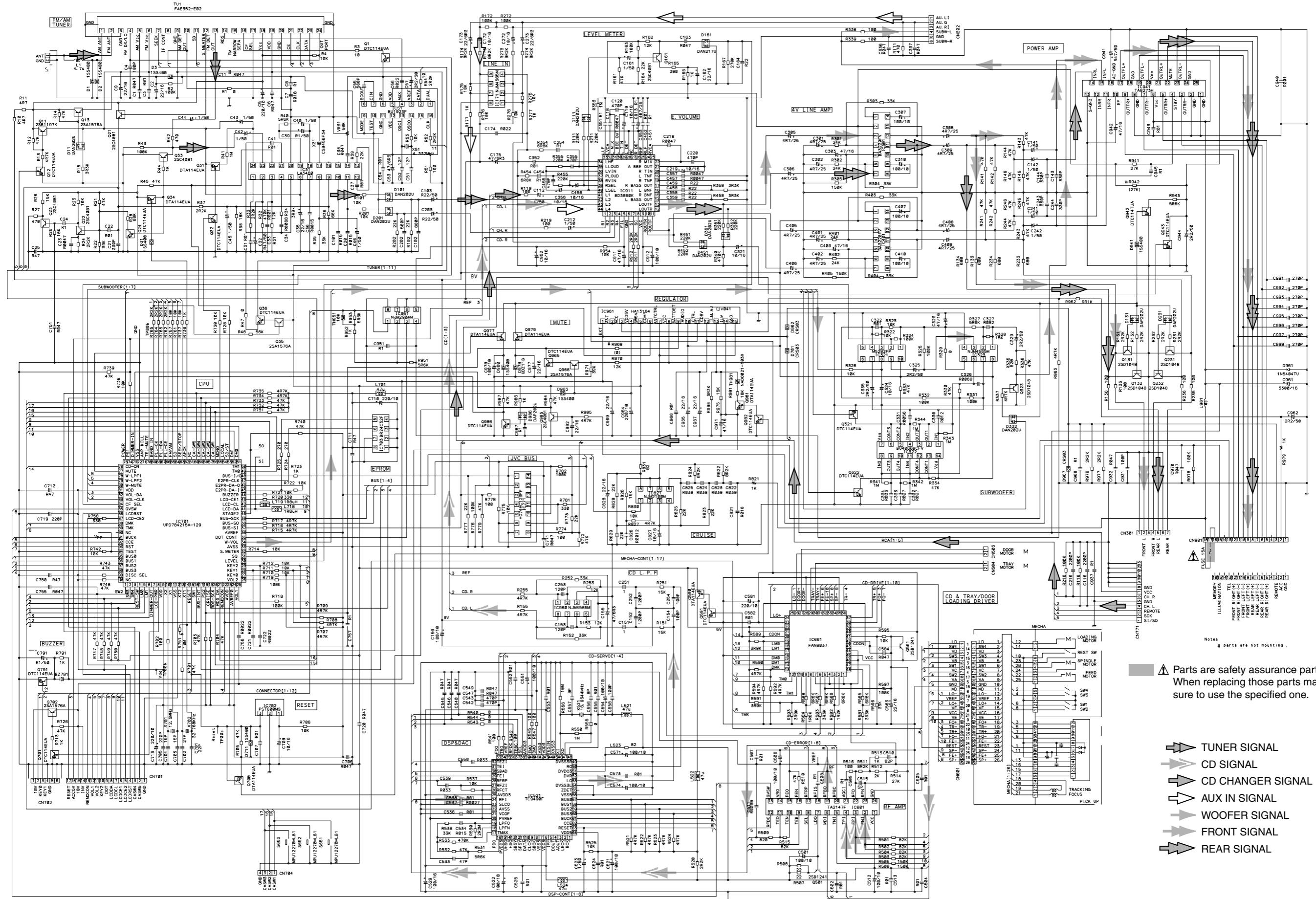

▲ Parts are safety assurance parts. When replacing those parts make sure to use the specified one.

- ➡ TUNER SIGNAL
- ➡ CD SIGNAL
- ➡ CD CHANGER SIGNAL
- ➡ AUX IN SIGNAL
- ➡ WOOFER SIGNAL
- ➡ FRONT SIGNAL
- ➡ REAR SIGNAL

Notes
 ▲ parts are not mounting.

KD-LX110R

5
4
3
2
1

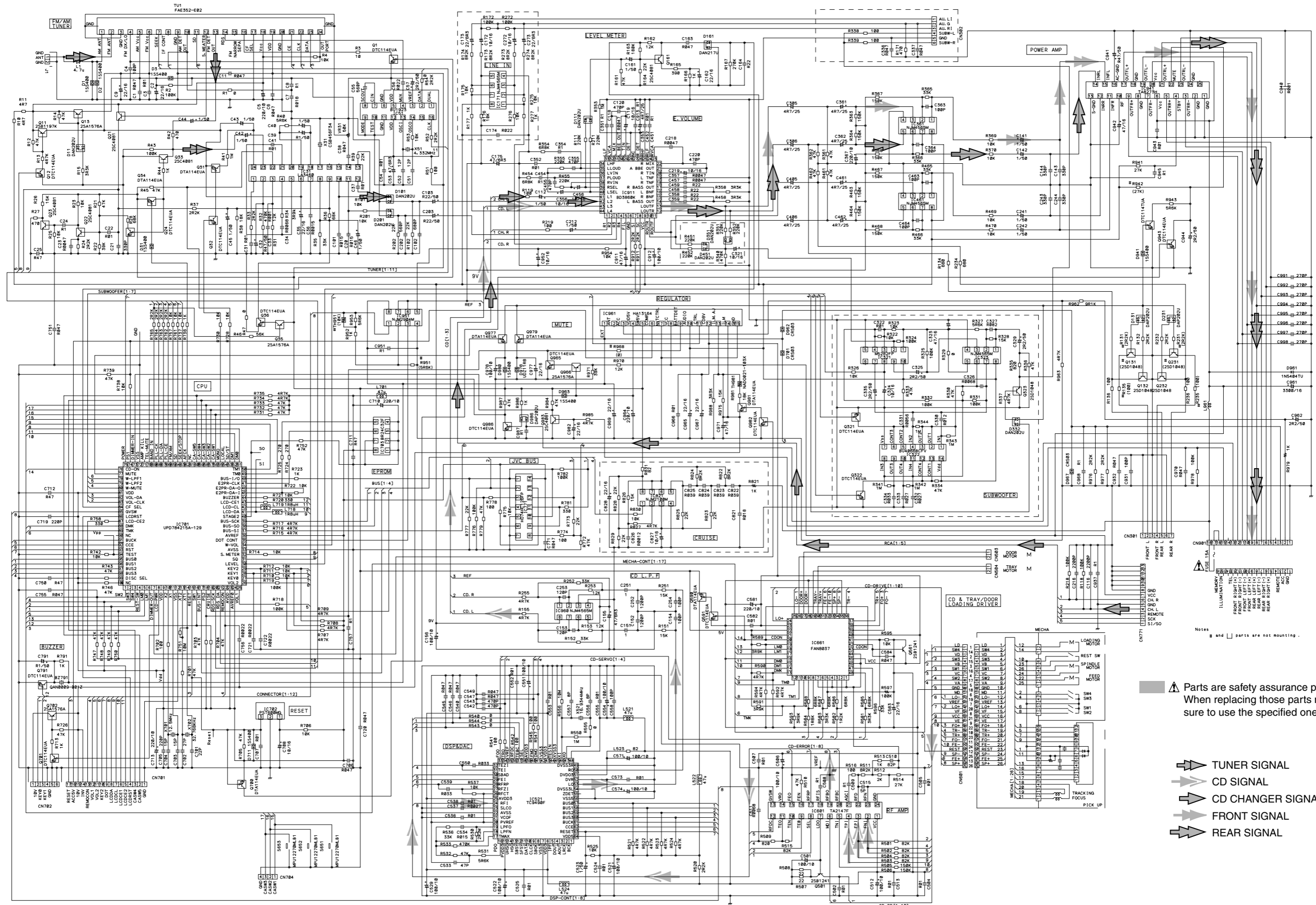

▲ Parts are safety assurance parts. When replacing those parts make sure to use the specified one.

- ➡ TUNER SIGNAL
- ➡ CD SIGNAL
- ➡ CD CHANGER SIGNAL
- ➡ FRONT SIGNAL
- ➡ REAR SIGNAL

CD servo, LCD & Key control section (KD-LX330R)

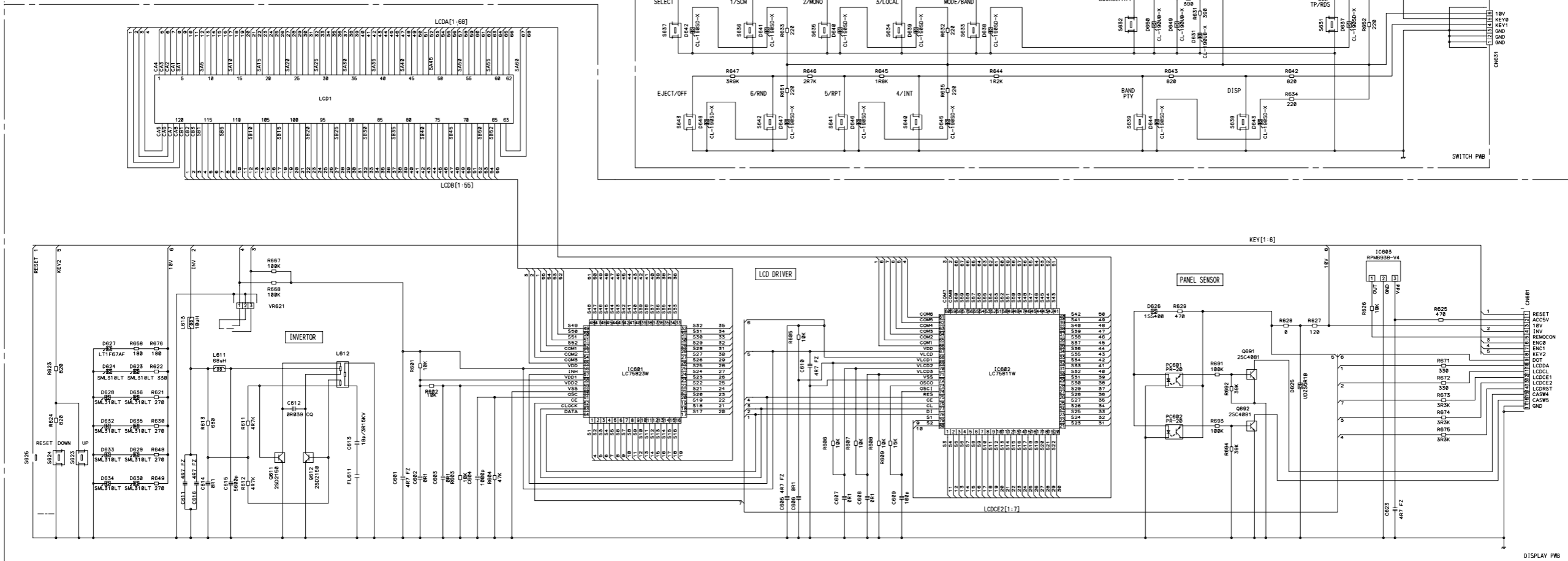

CD servo, LCD & Key control section (KD-LX110R)

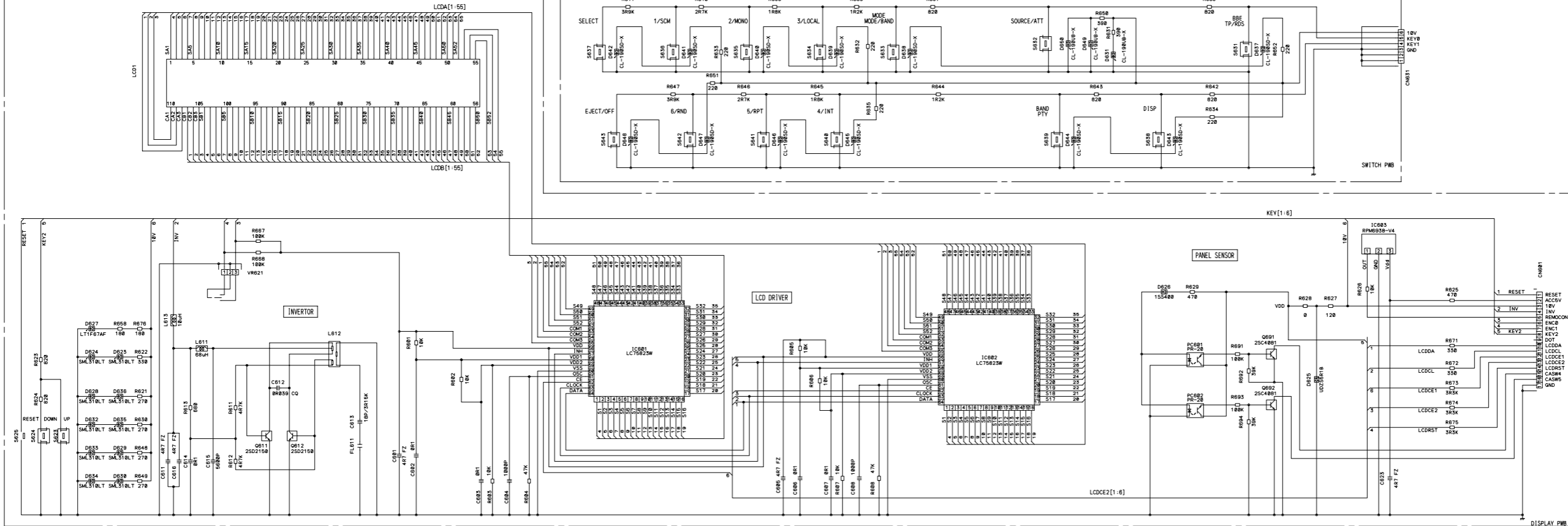

5

4

3

2

1

A

B

C

2-4

D

E

F

G

H

■ Parts list (General assembly)

Block No. M1MM

△	Item	Parts number	Parts name	Q'ty	Description	Area
	1	DG1002000	CHASSIS TOP	1		
	2	DG4114000	INSULATOR (SHAS	1		
	3	-----	CD MECHA	1		
	4	QYSDST2604Z	SCREW	3		
	5	DG4003020	FFC P.MECHA	1		
	6	QYSPST2004M	SCREW	1		
	7	DG1069001	FRONT COVER	1		
	8	LV40828-002A	BLIND	1		
	9	QYSPSP2003M	SCREW	2		
	10	LV31605-001A	DOOR BASE ASS'Y	1		
	11	DG4112010	PANEL COVER ASS	1		
	12	LV31610-001A	ROD GEAR	1		
	13	DG1073150	BUTTON PANEL	1	KD-LX110R	
		DG1073151	BUTTON PANEL	1	KD-LX330R	
	14	DG3024000	BUTTON BASE BKT	1		
	15	DG4071010	BUTTON B SUPORT	1		
	16	YM2029000	SCREW	3		
	17	LV41452-003A	TENS SPRING BTM	2		
	19	YM2029000	SCREW	4		
	20	DG1122001	DISPLAY PANEL	1		
	21	XP1728P3B	SCREW	4		
	22	EX0000496	17P FLAT CABLE	1		
	23	XT2640BSC	SCREW	8		
	24	DG3008000	SIDE HEAT SINK	1		
	25	XT26A0BPC	SCREW	1		
	26	YM2626002	SCREW	4		
	27	YM2626000	SCREW	1		
	28	LV41469-001A	UP DOWN B.ASS'Y	1		
	29	LV40848-009A	SPACER(P)	1		
	30	LV40846-005A	SPACER(F)	1		
	31	DG3126020	KNOB SPRING	1		
	32	DG4127010	ENCODER PLATE	1		
	33	DG3121050	KNOB VOL ASSY	1		
	34	VKZ4777-001	MINI SCREW	4		
	35	DG3102010	FINDER ASSY	1		
	36	DG4136000	D.P. PLATE	1		
	37	LV41505-001A	REMOTE LENS	1		
	38	QAR0029001-SA2	MOTOR ASS'Y	1		
	39	LV40847-002A	SPACER	1		
	40	KA2502009	2P CONECTOR ASS	1		
	41	DG4138000	MOTOR ASS'Y	1		
	42	LV40847-002A	SPACER	1		
	43	KA2502010	2P CONECTOR ASS	1		
	44	DG3131010	MOVE BKT ASS'Y	1		
	45	XP2020P1C	SCREW	4		
	46	DG3082030	PUSH LEVER ASSY	1		
	47	LV41466-001A	GEAR 4	1		
	48	LV41467-001A	GEAR 5	1		

■ Parts list (General assembly)

Block No. M1MM

△	Item	Parts number	Parts name	Q'ty	Description	Area
	49	LV30981-005A	CLUTCH ASS'Y	1		
	50	YWP020300	C.WASHER	7		
	51	YWP020301	C.WASHER	2		
	52	LV31611-001A	GEAR 3	1		
	53	LV41464-001A	GEAR 2	1		
	54	LV41463-001A	GEAR 1	1		
	55	LV30981-007A	*CLUTCH ASS'Y	1		
	56	DG4087040	LEVER SPRING	1		
	57	DG3058000	FFC GUIDE	1		
	58	DG3010010	BOTTOM ASSY	1		
	59	LV41545-001A	BUTTON B.GUIDE	1		
	60	YM2029000	SCREW	1		
	61	DG3014000	INSULATOR	1		
	62	YM2626000	SCREW	3		
	64	DG3092020	LIGHTING CASE	1		
	65	DG4090030	LCD FILTER	1		
	66	000101380	LCD	1	KD-LX110R	
		000101390	LCD	1	KD-LX330R	
	67	DG3089020	LCD CASE	1		
	68	DG4091020	ZEBRA CONTACT	2		
	69	EX0000495	6P FLAT CABLE	1		
	70	DG2074031	BUTTON PRESET 1	1		
	71	DG3075042	BUTTON PRESET 2	1		
	72	DG3076040	BUTTON SOURCE	1		
	73	DG1072090	BUTTON BASE	1		
	74	LV41825-004A	PLATE SPRING	1		
	75	VKZ4777-004	MINI SCREW	6		
	76	DG3070000	REG.IC BRACET	1		
	77	DG4117000	POWER IC BKT	1		
	78	DG3005030	REAR BRACKET	1		
	79	DG3007010	REAR HEAT SINK	1		
	80	XT2640BSC	SCREW	1		
	81	YM2626001	SCREW	3		
	82	XT2640BSC	SCREW	2		
△	83	FU15R0031	AUTO FUSE	1	(15A)	
	84	PLN122900	NAME LABEL	1	KD-LX110R	
		PLN123000	NAME LABEL	1	KD-LX330R	
	85	DG4115000	SHEET	2		
	87	DG3111000	LEAD PLATE	1		
	89	EX0000490	RCA CORD ASSY	1	KD-LX330R	
		EX0000488	RCA CORD ASSY	1	KD-LX110R	
	90	DG4116010	SHEET (FRONT BK	1		
	91	XT2040BSC	SCREW	1		
	92	EX0000508	WIRE ASS'Y	1		
	94	DG4124000	SPACER	1		

■ Parts list (CD mechanism)

Block No. M2MM

△	Item	Parts number	Parts name	Q'ty	Description	Area
	1	30310101T	FRAME	1		
	2	30310103T	DANPER PIN	2		
	3	30310107T	UPPER PLATE	1		
	4	30310108T	SEL STOP PLATE	1		
	5	30310142T	SEL ARM (L)L	1		
	6	30310143T	SEL ARM (R)L	1		
	7	30310145T	S ARM SPRING(L)	2		
	8	30310112T	TRIG LEVER	1		
	9	30310155T	TRIG PL(Z)	1		
	10	30310115T	TRIG PL SPRING	1		
	11	30310116T	TRIG ARM	1		
	12	30310134T	FIX ARM (L)B	1		
	13	30310159T	FIX ARM (R)Z	1		
	14	30310150T	FIX PL (L)Z	1		
	15	30310156T	FIX PL (R) Z	1		
	16	30310138T	LDG GR (6)B	1		
	17	30310122T	LDG GEAR (6)SP	1		
	18	30310148T	S.L ARM(N)	1		
	19	30310125T	S.L ARM SPRING	1		
	20	30310149T	REAR DAM BKT(Z)	1		
	22	30310151T	HUNG UP SP (FZ)	2		
	23	30310129T	HUNG UP SP (R)	2		
	29	30300510T	PU GEAR(B)	1		
	32	30310544T	F.M.BASE(Z)	1		
	33	30310547T	FD GR BLK(Z)	1		
	36	30310546T	PU GUIDE(Z)	1		
	38	30310533T	THRUST SPR(M)	1		
	39	30310577T	PU M NUT(Z-S)	1		
	40	30310512T	NUT PUSH SPR PL	1		
	41	30310558T	CLP ARM(Z)	1		
	42	30310514T	CLP ARM SPRING	1		
	43	30310552T	CLAMPER(Z)	1		
	48	30310557T	CLAMPER PLATE(Z)	1		
	49	30310524T	DAMPER (J)	3		
	50	30310525T	CLP ARM SPR (L)	1		
	51	30310545T	F SCREW GUIDE(Z)	1		
	56	64180405T	DET SW	1	ESE11SF4	
	57	QAL0230-001	C.D PICK (SONY)	1		
	61	30311035T	FPC HOLDER(Z)	1		
	62	19501403T	WIRE CLAMPER	4		
	63	30311045T	PICK UP FPC(Z-S)	1		
	64	30311044T	CONNECT.PCB(Z-S)	1		
	65	30311038T	WIRE (5P-Z)	1		
	66	30311039T	WIRE (LD-Z)	1		
	67	30311040T	WIRE (FD-Z)	1		
	68	30311041T	WIRE (RS-Z)	1		
	70	64180402T	DET SWITCH	2	ESE22MH1	
	71	64180403T	DET SWITCH	2	ESE22MH3	

■ Parts list (CD mechanism)

Block No. M2MM

△	Item	Parts number	Parts name	Q'ty	Description	Area
	72	68150232T	CONNECTOR	1	TKC-W26X-C1	
	79	30311105T	SOPPORT PLATE	1		
	80	30311138T	GR MT BLK(N)	1		
	81	30311109T	LDG GEAR (2)	1		
	82	30311110T	LDG GEAR (3)	1		
	84	30311112T	LDG GEAR (5)	1		
	86	30311136T	LDG ROLLER	2		
	88	30311118T	L.P SPRING (L)	1		
	89	30311119T	L.P SPRING (R)	1		
	90	30311123T	SW PCB	1		
	91	30311124T	SW ACTUATOR	1		
	92	30311129T	LDG BELT	1		
	93	30311140T	FRONT BRKT (J)	1		
	100	9C0620503T	C B TAP SCREW	2	M2X5	
	101	9C2020401T	C SCREW TS.G	5	M2X4	
	102	9C4320403T	C B TAP SCREW	4	M2X4	
	103	9C0117223T	SCREW	2	M1.7X2.2	
	104	9C0917703T	C TAP SCREW S3	1	M1.7X7	
	105	9C0320201T	C TAP SCREW S3	1	M2X2	
	106	9C4920013T	C TAP SCREW S3	2	M2X10	
	107	9C4920603T	C TAP SCREW B3	4	M2X6	
	108	9P0220031T	TAMS SCREW	2	M2X3	
	110	9C0420253	C TAP SCREW	1	M2X2.5	
	113	9W0330276	NW BLUE	2	2.9X5X0.3	
	116	9W0725030T	LUMILAR W	1	2.3X9.8X0.25	
	117	9W0640030T	WASHER	1	1.4X3.2X0.4	
	130	303105310T	FEED MO ASSY	1		
	131	303105311T	SPINDLE MO ASSY	1		
	132	303105312T	FEED SCREW ASSY	1		
	133	303111301T	LDG MOTOR ASSY	1		
	134	303111302T	RDG RLR SFT ASY	1		
	135	303105502T	T.T.BASE ASSY	1		

■ Electrical parts list (Main board)

Block No. 01

△	Item	Parts number	Parts name	Remarks	Area
	BZ791	000393760	BUZZER	CD11PA-XZ	
	C 1	CY473623J	CAPACITOR	CY 0.047 UF	
	C 2	CE2263468	CAPACITOR	CE 22UF 16V	
	C 3	CY103623J	CAPACITOR	CY 0.001 UF	
	C 4	CZ1016D2J	CAPACITOR	CZ 100PF	
	C 5	CE2271468	CAPACITOR	CY 0.01 UF	
	C 6	CY473623J	CAPACITOR	CY 0.047 UF	
	C 7	CY183623J	CAPACITOR	CE 0.018UF	
	C 8	CY104423J	CAPACITOR	CY 0.1UF	
	C 9	CE2263468	CAPACITOR	CE 22UF/16V	
	C 11	CY473623J	CAPACITOR	CY 0.047UF	
	C 20	CY153623J	CAPACITOR	CY 0.015UF	
	C 21	CZ3316D2J	CAPACITOR	CZ 330PF	
	C 22	CY103623J	CAPACITOR	CY0.01UF	
	C 23	CY472623J	CAPACITOR	CY 0.0047 UF	
	C 24	CY104423J	CAPACITOR	CY 0.1UF	
	C 25	CE4746468	CAPACITOR	CE 0.47UF/50V	
	C 31	CY103623J	CAPACITOR	CY 0.01 UF	
	C 32	CE4746468	CAPACITOR	CE 0.47UF/50V	
	C 33	CY102623J	CAPACITOR	CY 0.001 UF	
	C 34	CY682623J	CAPACITOR	CY 0.0068UF	
	C 35	CE2263468	CAPACITOR	CE 22 UF/16V	
	C 36	CY152623J	CAPACITOR	CY 0.0015UF	
	C 37	CY103623J	CAPACITOR	CY 0.01 UF	
	C 38	CY473623J	CAPACITOR	CY 0.047 UF	
	C 39	CE1046468	CAPACITOR	CE 0.1 UF/50V	
	C 40	CE1056468	CAPACITOR	CE 1 UF/50V	
	C 41	CY103623J	CAPACITOR	CY 0.01UF	
	C 42	CE1056468	CAPACITOR	CE 1 UF/50V	
	C 43	CE1056468	CAPACITOR	CE 1 UF/50V	
	C 44	CE1056468	CAPACITOR	CE 1 UF/50V	
	C 45	CE1056468	CAPACITOR	CE 1 UF/50V	
	C 46	CE1056468	CAPACITOR	CE 1 UF/50V	
	C 51	CZ1206D2J	CAPACITOR	CZ 12PF	
	C 52	CZ1206D2J	CAPACITOR	CZ 12PF	
	C 53	CE4760468	CAPACITOR	CE47 UF/6.3V	
	C 54	CY103623J	CAPACITOR	CY 0.01UF	
	C 55	CZ5616D2J	CAPACITOR	CZ 560 PF	
	C 56	CY223623J	CAPACITOR	CY 0.022UF	
	C 57	CE2256468	CAPACITOR	CE 2.2UF/50V	
	C 101	CY153623J	CAPACITOR	CY 0.015UF	
	C 102	CZ6816D2J	CAPACITOR	CZ 680 PF	
	C 103	CE2246468	CAPACITOR	CE 0.22UF/50V	
	C 112	CE1056468	CAPACITOR	CE 1 UF	
	C 118	CY472623J	CAPACITOR	CY 0.0047UF	
	C 119	CE1063468	CAPACITOR	CE 10 UF	
	C 120	CZ4716D2J	CAPACITOR	CZ 470 PF	
	C 141	CE1056468	CAPACITOR	CE 1 UF	
	C 142	CE1056468	CAPACITOR	CE 1 UF	
	C 143	CZ3316D2J	CAPACITOR	CZ 330 PF	
	C 144	CZ3316D2J	CAPACITOR	CZ 330 PF	
	C 151	CY105122J	CAPACITOR	CY 1 UF	
	C 152	CY122623J	CAPACITOR	CY 0.0012UF	
	C 153	CZ1216D2J	CAPACITOR	CZ 120 PF	
	C 154	CZ1016D2J	CAPACITOR	CZ 100 PF	
	C 155	CE4760468	CAPACITOR	CE 47 UF	
	C 156	CE1071468	CAPACITOR	CE 100 UF	
	C 161	CE1056468	CAPACITOR	CE 1 UF	
	C 162	CE2263468	CAPACITOR	CE 22 UF	
	C 163	CY473623J	CAPACITOR	CY 0.047 UF	
	C 164	CY224122J	CAPACITOR	CY 0.22 UF	
	C 172	CE1063468	CAPACITOR	KD-LX330R	
	C 173	CE2260468	CAPACITOR	KD-LX330R	

△	Item	Parts number	Parts name	Remarks	Area
	C 174	CY223623J	CAPACITOR	KD-LX330R	
	C 175	CE4760468	CAPACITOR	0.22 UF	
	C 202	CZ5616D2J	CAPACITOR	CZ 560 PF	
	C 203	CE2246468	CAPACITOR	CE 0.022UF/50V	
	C 212	CE1056468	CAPACITOR	CE 1 UF	
	C 218	CY472623J	CAPACITOR	CY 0.0047UF	
	C 219	CE1063468	CAPACITOR	CE 10 UF	
	C 220	CZ4716D2J	CAPACITOR	CZ 470 PF	
	C 241	CE1056468	CAPACITOR	CE 1 UF	
	C 242	CE1056468	CAPACITOR	CE 1 UF	
	C 243	CZ3316D2J	CAPACITOR	CZ 330 PF	
	C 244	CZ3316D2J	CAPACITOR	CZ 330 PF	
	C 251	CY105122J	CAPACITOR	CY 1 UF	
	C 252	CY122623J	CAPACITOR	CY 0.0012UF	
	C 253	CZ1216D2J	CAPACITOR	CZ 120 PF	
	C 254	CZ1016D2J	CAPACITOR	CZ 100 PF	
	C 272	CE1063468	CAPACITOR	KD-LX330R UF	
	C 273	CE2260468	CAPACITOR	KD-LX330R	
	C 301	CE4754468	CAPACITOR	KD-LX330R	
	C 302	CE4754468	CAPACITOR	KD-LX330R	
	C 303	CE4763468	CAPACITOR	KD-LX330R	
	C 305	CE4754468	CAPACITOR	4.7UF125V	
	C 306	CE4754468	CAPACITOR	4.7UF125V	
	C 307	CE1071468	CAPACITOR	KD-LX330R	
	C 308	CE4754468	CAPACITOR	KD-LX330R	
	C 309	CE4754468	CAPACITOR	KD-LX330R	
	C 310	CE1071468	CAPACITOR	KD-LX330R	
	C 321	CE1063468	CAPACITOR	KD-LX330R	
	C 322	CY103623J	CAPACITOR	KD-LX330R	
	C 323	CE4763468	CAPACITOR	KD-LX330R	
	C 324	CE1063468	CAPACITOR	KD-LX330R	
	C 325	CE2256468	CAPACITOR	KD-LX330R	
	C 326	CY682623J	CAPACITOR	KD-LX330R	
	C 327	CY823423J	CAPACITOR	KD-LX330R	
	C 329	CE2256468	CAPACITOR	KD-LX330R	
	C 330	CY123623J	CAPACITOR	KD-LX330R	
	C 331	CY562623J	CAPACITOR	KD-LX330R	
	C 332	CY273623J	CAPACITOR	KD-LX330R	
	C 333	CY273623J	CAPACITOR	KD-LX330R	
	C 334	CY333623J	CAPACITOR	KD-LX330R	
	C 335	CE2256468	CAPACITOR	KD-LX330R	
	C 336	CY473623J	CAPACITOR	KD-LX330R	
	C 337	CY473623J	CAPACITOR	KD-LX330R	
	C 351	CY104423J	CAPACITOR	CY 0.1 UF	
	C 352	CY103623J	CAPACITOR	CY 0.01 UF	
	C 353	CE4754468	CAPACITOR	CE 4.7 UF	
	C 354	CY104423J	CAPACITOR	CY 0.1 UF	
	C 355	CZ4716D2J	CAPACITOR	CZ 470 PF	
	C 356	CE1063468	CAPACITOR	CE 10 UF	
	C 357	CY472623J	CAPACITOR	CY 0.0047UF	
	C 358	CY224122J	CAPACITOR	CY 0.22 UF	
	C 359	CY224122J	CAPACITOR	CY 0.22 UF	
	C 361	CE4754468	CAPACITOR	KD-LX110R	
	C 362	CE4754468	CAPACITOR	KD-LX110R	
	C 363	CZ1016D2J	CAPACITOR	KD-LX110R	
	C 364	CZ1016D2J	CAPACITOR	KD-LX110R	
	C 367	CE2271468	CAPACITOR	KD-LX110R	
	C 401	CE4754468	CAPACITOR	KD-LX330R	
	C 402	CE4754468	CAPACITOR	KD-LX330R	
	C 403	CE4763468	CAPACITOR	KD-LX330R	
	C 405	CE4754468	CAPACITOR	4.7UF 125V	
	C 406	CE4754468	CAPACITOR	4.7UF 125V	
	C 407	CE1071468	CAPACITOR	KD-LX330R	

■ Electrical parts list (Main board)

Block No. 01

△	Item	Parts number	Parts name	Remarks	Area	△	Item	Parts number	Parts name	Remarks	Area
	C 408	CE4754468	CAPACITOR	KD-LX330R			C 701	CZ2206D2J	CAPACITOR	CZ 22 PF	
	C 409	CE4754468	CAPACITOR	KD-LX330R			C 702	CZ2706D2J	CAPACITOR	CZ 27 PF	
	C 410	CE1071468	CAPACITOR	KD-LX330R			C 703	CZ1506D2J	CAPACITOR	CZ 15 PF	
	C 451	CY104423J	CAPACITOR	CY 0.1 UF			C 704	CZ1506D2J	CAPACITOR	CZ 15 PF	
	C 452	CY103623J	CAPACITOR	CY 0.01 UF			C 705	CZ2216D2J	CAPACITOR	CZ 220 PF	
	C 454	CY104423J	CAPACITOR	CY 0.1 UF			C 706	CY473623J	CAPACITOR	CY 0.047 UF	
	C 455	CZ4716D2J	CAPACITOR	CZ 470 PF			C 707	CY103623J	CAPACITOR	CY 0.01 UF	
	C 456	CE1063468	CAPACITOR	CE 10 UF			C 708	CE1063468	CAPACITOR	CE 10 UF	
	C 457	CY472623J	CAPACITOR	CY 0.0047UF			C 710	CE2271468	CAPACITOR	CE 220 UF	
	C 458	CY224122J	CAPACITOR	CY 0.22 UF			C 711	CY474122J	CAPACITOR	CY 0.47 UF	
	C 459	CY224122J	CAPACITOR	CY 0.22 UF			C 712	CY474122J	CAPACITOR	CY 0.47 UF	
	C 461	CE4754468	CAPACITOR	KD-LX110R			C 713	CE2271468	CAPACITOR	CE 220 UF	
	C 462	CE4754468	CAPACITOR	KD-LX110R			C 719	CZ2216D2J	CAPACITOR	CZ 220 PF	
	C 463	CZ1016D2J	CAPACITOR	KD-LX110R			C 720	CY473623J	CAPACITOR	CY 0.047 UF	
	C 464	CZ1016D2J	CAPACITOR	KD-LX110R			C 721	CY222623J	CAPACITOR	CY 0.0022UF	
	C 501	CE1071468	CAPACITOR	CE 100 UF			C 722	CY222623J	CAPACITOR	CY 0.0022UF	
	C 502	CY103623J	CAPACITOR	CY 0.01 UF			C 723	CE2271468	CAPACITOR	KD-LX330R	
	C 504	CY103623J	CAPACITOR	CY 0.01 UF			C 730	CY473623J	CAPACITOR	CY 0.047UF	
	C 505	CY103623J	CAPACITOR	CY 0.01 UF			C 750	CY474122J	CAPACITOR	CY 0.47UF	
	C 506	CE1071468	CAPACITOR	CE 100 UF			C 755	CY473623J	CAPACITOR	CY 0.047 UF	
	C 507	CY103623J	CAPACITOR	CY 0.01 UF			C 756	CY222623J	CAPACITOR	CY 0.0022UF	
	C 508	CY104423J	CAPACITOR	CY 0.1 UF			C 757	CY104423J	CAPACITOR	CY 0.1 UF	
	C 509	CY104423J	CAPACITOR	CY 0.1 UF			C 771	CY473623J	CAPACITOR	CY 0.047 UF	
	C 510	CZ8206D2J	CAPACITOR	CZ 82 PF			C 791	CE1046468	CAPACITOR	CE 0.1 UF	
	C 511	CY682623J	CAPACITOR	CY 0.0068UF			C 821	CY183623J	CAPACITOR	KD-LX330R F	
	C 512	CE1071468	CAPACITOR	CE 100 UF			C 822	CY393623J	CAPACITOR	KD-LX330R	
	C 513	CY103623J	CAPACITOR	CY 0.01 UF			C 823	CY393623J	CAPACITOR	KD-LX330R	
	C 515	CZ5R06A2J	CAPACITOR	CZ 5 PF			C 824	CY393623J	CAPACITOR	KD-LX330R	
	C 521	CE1071468	CAPACITOR	CE 100 UF			C 825	CY393623J	CAPACITOR	KD-LX330R	
	C 522	CE1071468	CAPACITOR	CE 100 UF			C 826	CY122623J	CAPACITOR	KD-LX330R	
	C 523	CE1056468	CAPACITOR	CE 1 UF			C 827	CE1063468	CAPACITOR	KD-LX330R	
	C 524	CY103623J	CAPACITOR	CY 0.01 UF			C 828	CE2263468	CAPACITOR	KD-LX330R	
	C 525	CY103623J	CAPACITOR	CY 0.01 UF			C 911	CE4763468	CAPACITOR	CE 47 UF	
	C 529	CE1071468	CAPACITOR	CE 100 UF			C 912	CE1071468	CAPACITOR	CE 100 UF	
	C 533	CZ4706D2J	CAPACITOR	CZ 47 PF			C 913	CY104423J	CAPACITOR	CY 0.1 UF	
	C 534	CY153623J	CAPACITOR	CY 0.015 UF			C 931	CZ1016D2J	CAPACITOR	CZ 100 PF	
	C 536	CY103623J	CAPACITOR	CY 0.01 UF			C 932	CY473623J	CAPACITOR	CY 0.047 UF	
	C 537	CY272623J	CAPACITOR	CY 0.0027UF			C 937	CY104423J	CAPACITOR	CY 0.1 UF	
	C 538	CY103623J	CAPACITOR	CY 0.01 UF			C 940	CK1026057	CAPACITOR	KD-LX110R	
	C 539	CY333623J	CAPACITOR	CY 0.033 UF			C 941	CE4746468	CAPACITOR	CE 0.47 UF	
	C 540	CY473623J	CAPACITOR	CY 0.047 UF			C 942	CE4763468	CAPACITOR	CE 47 UF	
	C 542	CZ4716D2J	CAPACITOR	CZ 470 PF			C 943	CY103603J	CAPACITOR	CY 0.01 UF	
	C 543	CZ4716D2J	CAPACITOR	CZ 470 PF			C 944	CE2256468	CAPACITOR	CE 2.2UF 150V	
	C 545	CY473623J	CAPACITOR	CY 0.047 UF			C 945	CY104423J	CAPACITOR	CY 0.1 UF	
	C 546	CY473623J	CAPACITOR	CY 0.047 UF			C 951	CY104423J	CAPACITOR	CY 0.1 UF	
	C 547	CY473623J	CAPACITOR	CY 0.047 UF			C 952	CE1063468	CAPACITOR	CE 10 UF	
	C 549	CY473623J	CAPACITOR	CY 0.047 UF			C 961	CE3383541	CAPACITOR	CE 3300 UF	
	C 550	CY333623J	CAPACITOR	CY 0.033 UF			C 962	CE2256468	CAPACITOR	CE 2.2 UF	
	C 551	CE1071468	CAPACITOR	CE 100 UF			C 964	CE2271468	CAPACITOR	CE 220 UF	
	C 552	CY103623J	CAPACITOR	CY 0.01 UF			C 965	CE2263468	CAPACITOR	CE 22 UF	
	C 553	CY103623J	CAPACITOR	CY 0.01 UF			C 966	CY103623J	CAPACITOR	CY 0.01 UF	
	C 554	CE1071468	CAPACITOR	CE 100 UF			C 967	CE2263468	CAPACITOR	CE 22 UF	
	C 555	CY103623J	CAPACITOR	CY 0.01 UF			C 968	CY104423J	CAPACITOR	CY 0.1 UF	
	C 556	CZ8R06B2J	CAPACITOR	CZ 8 PF			C 969	CE2263468	CAPACITOR	CE 22 UF	
	C 557	CZ8R06B2J	CAPACITOR	CZ 8 PF			C 970	CY473623J	CAPACITOR	CY 0.047 UF	
	C 558	CZ1016D2J	CAPACITOR	CZ 100 PF			C 971	CE4763468	CAPACITOR	CE 47 UF	
	C 571	CE1071468	CAPACITOR	CE 100 UF			C 977	CE2263468	CAPACITOR	CE 22 UF	
	C 573	CY103623J	CAPACITOR	CY 0.01 UF			C 978	CE1071468	CAPACITOR	CE 100 UF	
	C 574	CE1071468	CAPACITOR	CE 100 UF			C 982	CE2263468	CAPACITOR	CE 22 UF	
	C 581	CE2271468	CAPACITOR	CE 220 UF			C 987	CY104423J	CAPACITOR	CY 0.1UF	
	C 582	CY103623J	CAPACITOR	CY 0.01 UF			C 991	CZ2716D2J	CAPACITOR	CZ 270PF	
	C 583	CE2263468	CAPACITOR	CE 22 UF			C 992	CZ2716D2J	CAPACITOR	CZ 270PF	
	C 584	CY473623J	CAPACITOR	CY 0.047 UF			C 993	CZ2716D2J	CAPACITOR	CZ 270PF	

■ Electrical parts list (Main board)

Block No. 01

△	Item	Parts number	Parts name	Remarks	Area
	C 994	CZ2716D2J	CAPACITOR	CZ 270PF	
	C 995	CZ2716D2J	CAPACITOR	CZ 270PF	
	C 996	CZ2716D2J	CAPACITOR	CZ 270PF	
	C 997	CZ2716D2J	CAPACITOR	CZ 270PF	
	C 998	CZ2716D2J	CAPACITOR	CZ 270PF	
	CN301	KN2507297	CONNECTOR	7P BASE POST	
	CN302	KN2506297	CONNECTOR	KD-LX330R	
	CN503	KN2502091	CONNECTOR	2P BASE POST S	
	CN504	KN2502091	CONNECTOR	2P BASE POST S	
	CN601	KZ042260L	CONNECTOR	26P TKC-W26P-	
	CN701	KZ041170L	CONNECTOR	17P FPC 52559-	
	CN702	KZ040060L	CONNECTOR	6P FPCR 52746-	
	CN704	KN530409L	CONNECTOR	4P BASE POST 5	
	CN771	KX0040800	CONNECTOR	8P BUS CONNECTO	
	CN901	KX0071600	CONNECTOR	DC CONNECTOR (1	
	D 1	DI1SS400L	DIODE		
	D 2	DI1SS400L	DIODE		
	D 3	DI1SS400L	DIODE		
	D 11	DAN202U-X	DIODE		
	D 31	DI1SS400L	SI,DIODE		
	D 101	DAN202U-X	DIODE		
	D 111	DAN202U-W	DIODE		
	D 131	DAP202U-X	DIODE		
	D 161	DIAN217UL	DIODE		
	D 201	DAN202U-X	SI,DIODE		
	D 231	DAP202U-X	DIODE		
	D 332	DAN202U-X	DIODE		
	D 351	DAN202U-X	DIODE	KD-LX330R	
	D 451	DAN202U-X	DIODE	KD-LX330R	
	D 701	CRS03-X	DIODE		
	D 711	DI1SS400L	DIODE		
	D 941	DI1SS400L	DIODE		
	D 961	1N5404-TU-15	DIODE		
	D 962	CRS03-X	DIODE		
	D 963	DI1SS400L	DIODE		
	D 967	CRS03-X	DIODE		
	D 978	UDZ11B-X	Z,DIODE	ZENER DI UDZ11	
	D 980	DI1SS400L	DIODE		
	D 986	DIAP202UL	DIODE		
	IC 31	LA3460M-X	IC		
	IC 51	BU1923F-X	IC		
	IC171	000474740-T	IC	KD-LX110R	
	IC301	BA3220FV-X	I.C(M)	KD-LX330R	
	IC321	M5282FP-X	I.C(MONO-ANA)	KD-LX330R	
	IC322	BU4066BCFV-X	IC	KD-LX330R	
	IC323	NJM4565MD	IC	KD-LX330R	
	IC361	NJM4565MD	IC	KD-LX110R	
	IC401	BA3220FV-X	I.C(M)	KD-LX330R	
	IC461	NJM4565MD	IC	KD-LX110R	
	IC521	TC9490FA	IC		
	IC601	TA2147F-X	IC		
	IC661	FAN8037	IC		
	IC701	UPD784215AGC129	IC		
	IC702	000874360-T	IC	IC PST600MGT	
	IC703	BR24C32F-X	IC		
	IC771	HD74HC126FP	IC		
	IC821	NJM2100M	I.C		
	IC821	TA8273H	I.C(MONO-ANA)	KD-LX330R	
	IC911	BD3860K	IC		
	IC941	TA8273H	I.C(MONO-ANA)		
	IC951	NJM2904M	IC		
	IC960	NJM4565MD	IC		
	IC961	HA13164	IC		

△	Item	Parts number	Parts name	Remarks	Area
	J 1	EX0000487	JACK	ANTTENA CORD AS	
	L 1	LC4R7J257	COIL	LC 4.7UH	
	L 521	LC470K10J	COIL	LC 47UH	
	L 522	LC470K10J	COIL	LC 47UH	
	L 523	RK820J32J	COIL	RK 1/4W 82K	
	L 524	LC470K10J	COIL	LC 47UH	
	L 701	LC470K10J	COIL	LC 47UH	
	L 718	LC1R8K24J	COIL	LC 1.8UH	
	L 719	LC1R8K24J	COIL	LC 1.8UH	
	L 961	000125560	CHOKO COIL		
	Q 1	DTA114EUA-X	DIGITAL.TR		
	Q 11	2SB1197K/QR/-X	TRANSISTOR		
	Q 12	TRC114EUL-A	TRANSISTOR		
	Q 13	TRA1576(QRS)L-A	TRANSISTOR		
	Q 21	TRC4081(QRS)L	TRANSISTOR		
	Q 22	TRC4081(QRS)L	TRANSISTOR		
	Q 23	TRC4081(QRS)L	TRANSISTOR		
	Q 24	TRC114EUL-A	TRANSISTOR		
	Q 31	TRA114EUL-A	TRANSISTOR		
	Q 32	TRC114EUL-A	TRANSISTOR		
	Q 33	TRC4081(QRS)L	TRANSISTOR		
	Q 34	TRA114EUL-A	TRANSISTOR		
	Q 35	TRA1576(QRS)L-A	TRANSISTOR		
	Q 36	TRC114EUL-A	TRANSISTOR		
	Q 131	2SD1048/6-7/-X	TRANSISTOR	KD-LX330R	
	Q 132	2SD1048/6-7/-X	TRANSISTOR		
	Q 161	2SC4081/QR/-X	TRANSISTOR		
	Q 231	2SD1048/6-7/-X	TRANSISTOR	KD-LX330R	
	Q 232	2SD1048/6-7/-X	TRANSISTOR		
	Q 321	TRC114EUL-A	TRANSISTOR	KD-LX330R	
	Q 322	TRC114EUL-A	TRANSISTOR	KD-LX330R	
	Q 323	2SD1048/6-7/-X	TRANSISTOR	KD-LX330R	
	Q 501	2SB1241/QR/-T	TRANSISTOR		
	Q 561	2SB1241/QR/-T	TRANSISTOR		
	Q 590	DTA114EUA-X	DIGITAL.TR		
	Q 591	DTA114EUA-X	DIGITAL.TR		
	Q 700	DTA114EUA-X	DIGITAL.TR		
	Q 701	DTA114EUA-X	DIGITAL.TR		
	Q 702	2SA1576A/QR/-X	TRANSISTOR		
	Q 791	DTA114EUA-X	DIGITAL.TR		
	Q 942	DTA114EUA-X	DIGITAL.TR		
	Q 943	DTA114EUA-X	DIGITAL.TR		
	Q 966	2SA1576A/QR/-X	TRANSISTOR		
	Q 977	DTA114EUA-X	DIGITAL.TR		
	Q 979	DTA114EUA-X	DIGITAL.TR		
	Q 981	DTA114EUA-X	DIGITAL.TR		
	Q 982	DTA114EUA-X	DIGITAL.TR		
	Q 983	2SC4081/QR/-X	TRANSISTOR		
	Q 986	TRC114EUL-A	TRANSISTOR		
	R 1	RK000JA0J	RESISTOR	RK 1/10W 0	
	R 2	RK104JA0J	RESISTOR	RK 1/10W 100 K	
	R 3	RK100JA0J	RESISTOR	RK 1/10W 10	
	R 4	RK103JA0J	RESISTOR	RK 1/10W 10K	
	R 10	RK4R7JA0J	RESISTOR	RK 1/10W 4.7	
	R 11	RK4R7JA0J	RESISTOR	RK 1/10W 4.7	
	R 12	RK473JA0J	RESISTOR	RK 1/10W 47 K	
	R 13	RK472JA0J	RESISTOR	RK 1/10W 4.7K	
	R 14	RK473JA0J	RESISTOR	RK 1/10W 47 K	
	R 15	RK332JA0J	RESISTOR	RK1/10W 3.3K	
	R 21	RK473JA0J	RESISTOR	RK 1/10W 47K	
	R 22	RK393JA0J	RESISTOR	RK 1/10W 39K	
	R 23	RK103JA0J	RESISTOR	RK 1/10W 10K	
	R 23	RK222JA0J	RESISTOR	RK 1/10W 2.2K	

■ Electrical parts list (Main board)

Block No. 01

△	Item	Parts number	Parts name	Remarks	Area	△	Item	Parts number	Parts name	Remarks	Area
	R 24	RK222JA0J	RESISTOR	RK 1/10W 2.2K			R 201	RK682JA0J	RESISTOR	RK 1/10W 6.8K	
	R 25	RK103JA0J	RESISTOR	RK 1/10W 10K			R 202	RK223JA0J	RESISTOR	RK 1/10W 22K	
	R 26	RK153JA0J	RESISTOR	RK 1/10W 15K			R 211	RK224JA0J	RESISTOR	RK 1/10W 220K	
	R 27	RK471JA0J	RESISTOR	RK 1/10W 470			R 218	RK104JA0J	RESISTOR	RK 1/10W 100K	
	R 27	RK393JA0J	RESISTOR	RK 1/10W 39K			R 219	RK101JA0J	RESISTOR	RK 1/10W 100	
	R 28	RK683JA0J	RESISTOR	RK 1/10W 68K			R 231	RK222JA0J	RESISTOR	KD-LX330R	
	R 28	RK103JA0J	RESISTOR	RK 1/10W 10K			R 231	RK222JA0J	RESISTOR	RK 1/10W 2.2K	
	R 31	RK123JA0J	RESISTOR	RK 1/10W 12K			R 232	RK222JA0J	RESISTOR	RK 1/10W 2.2K	
	R 32	RK474JA0J	RESISTOR	RK 1/10W 470K			R 233	RK681JA0J	RESISTOR	KD-LX330R	
	R 33	RK222JA0J	RESISTOR	RK 1/10W 2.2K			R 234	RK681JA0J	RESISTOR	RK 1/10W 680	
	R 34	RK392JA0J	RESISTOR	RK 1/10W 3.9K			R 235	RK101JA0J	RESISTOR	KD-LX330R	
	R 35	RK333JA0J	RESISTOR	RK 1/10W 33K			R 235	RK101JA0J	RESISTOR	RK 1/10W 100K	
	R 36	RK683JA0J	RESISTOR	RK 1/10W 68K			R 236	RK101JA0J	RESISTOR	RK 1/10W 100	
	R 37	RK222JA0J	RESISTOR	RK 1/10W 2.2K			R 241	RK473JA0J	RESISTOR	KD-LX330R	
	R 38	RK183JA0J	RESISTOR	RK 1/10W 18K			R 242	RK473JA0J	RESISTOR	KD-LX330R	
	R 39	RK223JA0J	RESISTOR	RK 1/10W 22K			R 243	RK473JA0J	RESISTOR	KD-LX330R	
	R 40	RK562JA0J	RESISTOR	RK 1/10W 5.6K			R 244	RK473JA0J	RESISTOR	KD-LX330R	
	R 41	RK105JA0J	RESISTOR	RK 1/10W 1M			R 245	RK473JA0J	RESISTOR	KD-LX330R	
	R 42	RK471JA0J	RESISTOR	RK 1/10W 470			R 246	RK473JA0J	RESISTOR	KD-LX330R	
	R 43	RK104JA0J	RESISTOR	RK 1/10W 100K			R 251	RK153JA0J	RESISTOR	RK 1/10W 15	
	R 44	RK102JA0J	RESISTOR	RK 1/10W 1K			R 252	RK333JA0J	RESISTOR	RK 1/10W 33K	
	R 45	RK473JA0J	RESISTOR	RK 1/10W 47K			R 253	RK123JA0J	RESISTOR	RK 1/10W 12K	
	R 46	RK563JA0J	RESISTOR	RK 1/10W 56K			R 255	RK472JA0J	RESISTOR	RK 1/10W 4.7K	
	R 47	RK000JA0J	RESISTOR	RK 1/10W 0K			R 272	RK104JA0J	RESISTOR	KD-LX330R	
	R 51	RK101JA0J	RESISTOR	RK 1/10W 100K			R 273	RK822JA0J	RESISTOR	KD-LX330R	
	R 52	RK222JA0J	RESISTOR	RK 1/10W 2.2K			R 274	RK822JA0J	RESISTOR	KD-LX330R	
	R 53	RK103JA0J	RESISTOR	RK 1/10W 10K			R 275	RK103JA0J	RESISTOR	KD-LX330R	
	R 54	RK222JA0J	RESISTOR	RK 1/10W 2.2K			R 276	RK103JA0J	RESISTOR	KD-LX330R	
	R 101	RK682JA0J	RESISTOR	RK 1/10W 6.8K			R 277	RK102JA0J	RESISTOR	KD-LX330R	
	R 102	RK223JA0J	RESISTOR	RK 1/10W 22K			R 301	RK243JA0J	RESISTOR	KD-LX330R	
	R 111	RK224JA0J	RESISTOR	RK 1/10W 220K			R 302	RK243JA0J	RESISTOR	KD-LX330R	
	R 118	RK104JA0J	RESISTOR	RK 1/10W 100K			R 303	RK333JA0J	RESISTOR	KD-LX330R	
	R 119	RK101JA0J	RESISTOR	RK 1/10W 100			R 304	RK333JA0J	RESISTOR	KD-LX330R	
	R 131	RK222JA0J	RESISTOR	KD-LX330R			R 305	RK154JA0J	RESISTOR	KD-LX330R	
	R 132	RK222JA0J	RESISTOR	RK 1/10W 2.2K			R 322	RK103JA0J	RESISTOR	KD-LX330R	
	R 133	RK681JA0J	RESISTOR	KD-LX110R			R 323	RK103JA0J	RESISTOR	KD-LX330R	
	R 134	RK681JA0J	RESISTOR	RK 1/10W 680			R 324	RK104JA0J	RESISTOR	KD-LX330R	
	R 135	RK101JA0J	RESISTOR	KD-LX330R			R 325	RK104JA0J	RESISTOR	KD-LX330R	
	R 136	RK101JA0J	RESISTOR	RK 1/10W 100			R 326	RK103JA0J	RESISTOR	KD-LX330R	
	R 141	RK473JA0J	RESISTOR	KD-LX330R			R 327	RK562JA0J	RESISTOR	KD-LX330R	
	R 142	RK473JA0J	RESISTOR	KD-LX330R			R 328	RK153JA0J	RESISTOR	KD-LX330R	
	R 143	RK473JA0J	RESISTOR	KD-LX330R			R 329	RK000JA0J	RESISTOR	KD-LX330R	
	R 144	RK473JA0J	RESISTOR	KD-LX330R			R 330	RK473JA0J	RESISTOR	KD-LX330R	
	R 145	RK473JA0J	RESISTOR	KD-LX110R			R 331	RK104JA0J	RESISTOR	KD-LX330R	
	R 146	RK473JA0J	RESISTOR	KD-LX110R			R 332	RK104JA0J	RESISTOR	KD-LX330R	
	R 151	RK153JA0J	RESISTOR	RK 1/10W 15			R 333	RK473JA0J	RESISTOR	KD-LX330R	
	R 152	RK333JA0J	RESISTOR	RK 1/10W 33K			R 334	RK473JA0J	RESISTOR	KD-LX330R	
	R 153	RK123JA0J	RESISTOR	RK 1/10W 12K			R 335	RK821JA0J	RESISTOR	KD-LX330R	
	R 155	RK472JA0J	RESISTOR	RK 1/10W 4.7K			R 336	RK473JA0J	RESISTOR	KD-LX330R	
	R 161	RK473JA0J	RESISTOR	RK 1/10W 47K			R 337	RK472JA0J	RESISTOR	KD-LX330R	
	R 162	RK123JA0J	RESISTOR	RK 1/10W 12K			R 338	RK101JA0J	RESISTOR	KD-LX330R	
	R 163	RK184JA0J	RESISTOR	RK 1/10W 180K			R 339	RK101JA0J	RESISTOR	KD-LX330R	
	R 164	RK223JA0J	RESISTOR	RK 1/10W 22K			R 340	RK474JA0J	RESISTOR	KD-LX330R	
	R 165	RK391JA0J	RESISTOR	RK 1/10W 390			R 341	RK105JA0J	RESISTOR	KD-LX330R	
	R 166	RK102JA0J	RESISTOR	RK 1/10W 1K			R 342	RK105JA0J	RESISTOR	KD-LX330R	
	R 167	RK274JA0J	RESISTOR	RK 1/10W 270K			R 343	RK105JA0J	RESISTOR	KD-LX330R	
	R 171	RK471JA0J	RESISTOR	KD-LX330R			R 344	RK105JA0J	RESISTOR	KD-LX330R	
	R 172	RK104JA0J	RESISTOR	KD-LX330R			R 351	RK224JA0J	RESISTOR	KD-LX330R	
	R 173	RK822JA0J	RESISTOR	KD-LX330R			R 352	RK224JA0J	RESISTOR	KD-LX330R	
	R 174	RK822JA0J	RESISTOR	KD-LX330R			R 353	RK105JA0J	RESISTOR	RK 1/10W 1M	
	R 175	RK103JA0J	RESISTOR	KD-LX330R			R 354	RK682JA0J	RESISTOR	RK 1/10W 6.8K	
	R 176	RK103JA0J	RESISTOR	KD-LX330R			R 355	RK224JA0J	RESISTOR	RK 1/10W 220K	
	R 177	RK102JA0J	RESISTOR	KD-LX330R			R 358	RK332JA0J	RESISTOR	RK 1/10W 3.3K	

■ Electrical parts list (Main board)

Block No. 01

△	Item	Parts number	Parts name	Remarks	Area
	R 361	RK473JA0J	RESISTOR	KD-LX110R	
	R 362	RK473JA0J	RESISTOR	KD-LX110R	
	R 363	RK154JA0J	RESISTOR	KD-LX110R	
	R 364	RK154JA0J	RESISTOR	KD-LX110R	
	R 365	RK333JA0J	RESISTOR	KD-LX110R	
	R 366	RK333JA0J	RESISTOR	KD-LX110R	
	R 367	RK154JA0J	RESISTOR	KD-LX110R	
	R 368	RK154JA0J	RESISTOR	KD-LX110R	
	R 369	RK103JA0J	RESISTOR	KD-LX110R	
	R 370	RK103JA0J	RESISTOR	KD-LX110R	
	R 401	RK243JA0J	RESISTOR	KD-LX330R	
	R 402	RK243JA0J	RESISTOR	KD-LX330R	
	R 403	RK333JA0J	RESISTOR	KD-LX330R	
	R 404	RK333JA0J	RESISTOR	KD-LX330R	
	R 405	RK154JA0J	RESISTOR	KD-LX330R	
	R 451	RK224JA0J	RESISTOR	KD-LX330R	
	R 452	RK224JA0J	RESISTOR	KD-LX330R	
	R 454	RK682JA0J	RESISTOR	RK 1/10W 6.8K	
	R 455	RK224JA0J	RESISTOR	RK 1/10W 220K	
	R 458	RK332JA0J	RESISTOR	RK 1/10W 3.3K	
	R 461	RK473JA0J	RESISTOR	KD-LX110R	
	R 462	RK473JA0J	RESISTOR	KD-LX110R	
	R 463	RK154JA0J	RESISTOR	KD-LX110R	
	R 464	RK154JA0J	RESISTOR	KD-LX110R	
	R 465	RK333JA0J	RESISTOR	KD-LX110R	
	R 466	RK333JA0J	RESISTOR	KD-LX110R	
	R 467	RK154JA0J	RESISTOR	KD-LX110R	
	R 468	RK154JA0J	RESISTOR	KD-LX110R	
	R 469	RK103JA0J	RESISTOR	KD-LX110R	
	R 470	RK103JA0J	RESISTOR	KD-LX110R	
	R 501	RK823JA0J	RESISTOR	RK 1/10W 82K	
	R 502	RK823JA0J	RESISTOR	RK 1/10W 82K	
	R 503	RK823JA0J	RESISTOR	RK 1/10W 82K	
	R 504	RK823JA0J	RESISTOR	RK 1/10W 82K	
	R 505	RK154JA0J	RESISTOR	RK 1/10W 150K	
	R 506	RK154JA0J	RESISTOR	RK 1/10W 150K	
	R 507	RK220JA0J	RESISTOR	RK 1/10W 22	
	R 508	RK220JA0J	RESISTOR	RK 1/10W 22	
	R 509	RK821JA1J	RESISTOR	RK 1/10W 820	
	R 510	RK473JA0J	RESISTOR	RK 1/10W 47K	
	R 511	RK822JA0J	RESISTOR	RK 1/10W 8.2K	
	R 512	RK202JA0J	RESISTOR	RK 1/10W 2K	
	R 513	RK102JA0J	RESISTOR	RK 1/10W 1K	
	R 514	RK273JA0J	RESISTOR	RK 1/10W 27K	
	R 515	RK823JA0J	RESISTOR	RK 1/10W 82K	
	R 516	RK101JA0J	RESISTOR	RK 1/10W 100	
	R 520	RK222JA0J	RESISTOR	RK 1/10W 2.2K	
	R 521	RK472JA0J	RESISTOR	RK 1/10W 4.7K	
	R 522	RK472JA0J	RESISTOR	RK 1/10W 4.7K	
	R 523	RK472JA0J	RESISTOR	RK 1/10W 4.7K	
	R 524	RK472JA0J	RESISTOR	RK 1/10W 4.7K	
	R 525	RK103JA0J	RESISTOR	RK 1/10W 10K	
	R 530	RK225JA0J	RESISTOR	RK 1/10W 2.2K	
	R 531	RK562JA0J	RESISTOR	RK 1/10W 5.6K	
	R 532	RK473JA0J	RESISTOR	RK 1/10W 47K	
	R 533	RK474JA0J	RESISTOR	RK 1/10W 470K	
	R 536	RK333JA0J	RESISTOR	RK 1/10W 33K	
	R 537	RK103JA0J	RESISTOR	RK 1/10W 10K	
	R 540	RK000JA0J	RESISTOR	RK 1/10W 0	
	R 541	RK101JA0J	RESISTOR	RK 1/10W 100	
	R 542	RK101JA0J	RESISTOR	RK 1/10W 100	
	R 543	RK000JA0J	RESISTOR	RK 1/10W 0	
	R 544	RK000JA0J	RESISTOR	RK 1/10W 0	

△	Item	Parts number	Parts name	Remarks	Area
	R 545	RK101JA0J	RESISTOR	RK 1/10W 100	
	R 547	RK101JA0J	RESISTOR	RK 1/10W 100	
	R 550	RK105JA0J	RESISTOR	RK 1/10W 1M	
	R 555	RK000JA0J	RESISTOR	RK 1/10W 0	
	R 556	RK106JA0J	RESISTOR	RK 1/10W 10M	
	R 581	RK332JA0J	RESISTOR	RK 1/10W 3.3K	
	R 582	RK122JA0J	RESISTOR	RK 1/10W 1.2K	
	R 583	RK332JA0J	RESISTOR	RK 1/10W 3.3K	
	R 584	RK182JA0J	RESISTOR	RK 1/10W 1.8	
	R 585	RK682JA0J	RESISTOR	RK 1/10W 6.8K	
	R 586	RK682JA0J	RESISTOR	RK 1/10W 6.8K	
	R 587	RK682JA0J	RESISTOR	RK 1/10W 6.8K	
	R 588	RK682JA0J	RESISTOR	RK 1/10W 6.8K	
	R 589	RK392JA0J	RESISTOR	RK 1/10W 3.9K	
	R 590	RK472JA0J	RESISTOR	RK 1/10W 4.7K	
	R 591	RK392JA0J	RESISTOR	RK 1/10W 3.9K	
	R 592	RK472JA0J	RESISTOR	RK 1/10W 4.7K	
	R 593	RK392JA0J	RESISTOR	RK 1/10W 3.9K	
	R 594	RK472JA0J	RESISTOR	RK 1/10W 4.7K	
	R 595	RK103JA0J	RESISTOR	RK 1/10W 10K	
	R 596	RK333JA0J	RESISTOR	RK 1/10W 33K	
	R 597	RD104J3CC	RESISTOR	RD 1/4W 100K	
	R 701	RK473JA0J	RESISTOR	RK 1/10W 47K	
	R 702	RK101JA0J	RESISTOR	RK 1/10W 100	
	R 703	RK473JA0J	RESISTOR	RK 1/10W 47K	
	R 704	RK473JA0J	RESISTOR	RK 1/10W 47K	
	R 705	RK473JA0J	RESISTOR	RK 1/10W 47K	
	R 706	RK103JA0J	RESISTOR	RK 1/10W 10K	
	R 707	RK472JA0J	RESISTOR	RK 1/10W 4.7K	
	R 708	RK472JA0J	RESISTOR	RK 1/10W 4.7K	
	R 709	RK472JA0J	RESISTOR	RK 1/10W 4.7K	
	R 710	RK103JA0J	RESISTOR	RK 1/10W 10K	
	R 711	RK103JA0J	RESISTOR	RK 1/10W 10K	
	R 712	RK103JA0J	RESISTOR	RK 1/10W 10K	
	R 713	RK222JA0J	RESISTOR	RK 1/10W 2.2K	
	R 714	RK103JA0J	RESISTOR	RK 1/10W 10K	
	R 715	RK472JA0J	RESISTOR	RK 1/10W 4.7K	
	R 716	RK472JA0J	RESISTOR	RK 1/10W 4.7K	
	R 717	RK472JA0J	RESISTOR	RK 1/10W 4.7K	
	R 718	RK104JA0J	RESISTOR	RK 1/10W 100K	
	R 719	RK104JA0J	RESISTOR	RK 1/10W 100K	
	R 720	RK331JA0J	RESISTOR	RK 1/10W 330	
	R 721	RK103JA0J	RESISTOR	RK 1/10W 10K	
	R 722	RK103JA0J	RESISTOR	RK 1/10W 10K	
	R 723	RK102JA0J	RESISTOR	RK 1/10W 1K	
	R 724	RK271JA0J	RESISTOR	RK 1/10W 270	
	R 725	RK271JA0J	RESISTOR	RK 1/10W 270	
	R 726	RK473JA0J	RESISTOR	RK 1/10W 47K	
	R 728	RK103JA0J	RESISTOR	RK 1/10W 10K	
	R 730	RK103JA0J	RESISTOR	RK 1/10W 10K	
	R 731	RK473JA0J	RESISTOR	RK 1/10W 47K	
	R 732	RK473JA0J	RESISTOR	RK 1/10W 47K	
	R 733	RK473JA0J	RESISTOR	RK 1/10W 47K	
	R 734	RK472JA0J	RESISTOR	RK 1/10W 4.7K	
	R 735	RK472JA0J	RESISTOR	RK 1/10W 4.7K	
	R 736	RK102JA0J	RESISTOR	RK 1/10W 1K	
	R 737	RK103JA0J	RESISTOR	RK 1/10W 10K	
	R 738	RK103JA0J	RESISTOR	RK 1/10W 10K	
	R 739	RK473JA0J	RESISTOR	RK 1/10W 47K	
	R 740	RK473JA0J	RESISTOR	KD-LX330R	
	R 742	RK103JA0J	RESISTOR	RK 1/10W 10K	
	R 743	RK473JA0J	RESISTOR	RK 1/10W 47K	
	R 746	RK473JA0J	RESISTOR	RK 1/10W 47K	

■ Electrical parts list (Main board)

Block No. 01

△	Item	Parts number	Parts name	Remarks	Area
	R 747	RK473JA0J	RESISTOR	RK 1/10W 47K	
	R 748	RK473JA0J	RESISTOR	RK 1/10W 47K	
	R 749	RK473JA0J	RESISTOR	RK 1/10W 47K	
	R 750	RK473JA0J	RESISTOR	RK 1/10W 47K	
	R 751	RK106JA0J	RESISTOR	RK 1/10W 10M	
	R 752	RK473JA0J	RESISTOR	KD-LX110R	
	R 757	RK103JA0J	RESISTOR	RK 1/10W 10K	
	R 758	RK331JA0J	RESISTOR	RK 1/10W 330	
	R 761	RK103JA0A	RESISTOR	RK1/10W 10 K	
	R 762	RK222JA0J	RESISTOR	RK1/10W 2.2K	
	R 763	RK222JA0J	RESISTOR	RK1/10W 2.2K	
	R 764	RK222JA0J	RESISTOR	RK1/10W 2.2K	
	R 765	RK222JA0J	RESISTOR	RK1/10W 2.2K	
	R 772	RK473JA0J	RESISTOR	RK 1/10W 47K	
	R 773	RK223JA0J	RESISTOR	RK 1/10W 22K	
	R 774	RK101JA0J	RESISTOR	RK 1/10W 100	
	R 775	RK103JA0J	RESISTOR	RK 1/10W 10K	
	R 776	RK104JA0J	RESISTOR	RK 1/10W 100K	
	R 777	RK223JA0J	RESISTOR	RK 1/10W 22K	
	R 778	RK101JA0J	RESISTOR	RK 1/10W 100	
	R 779	RK473JA0J	RESISTOR	RK 1/10W 47K	
	R 781	RK331JA0J	RESISTOR	RK 1/10W 330	
	R 782	RK104JA0J	RESISTOR	RK 1/10W 100K	
	R 791	RK102JA0J	RESISTOR	RK 1/10W 1K	
	R 821	RD102J3CQ	RESISTOR	KD-LX330R	
	R 822	RK822JA0J	RESISTOR	KD-LX330R	
	R 823	RK223JA0J	RESISTOR	KD-LX330R	
	R 824	RK822JA0J	RESISTOR	KD-LX330R	
	R 825	RK223JA0J	RESISTOR	KD-LX330R 22K	
	R 826	RK153JA0J	RESISTOR	KD-LX330R	
	R 827	RK472JA0J	RESISTOR	KD-LX330R	
	R 828	RK223JA0J	RESISTOR	KD-LX330R	
	R 829	RK223JA0J	RESISTOR	KD-LX330R	
	R 830	RK103JA0J	RESISTOR	KD-LX330R	
	R 831	RK820JA0J	RESISTOR	KD-LX330R	
	R 911	RK222JA0J	RESISTOR	RK 1/10W 2.2K	
	R 912	RK222JA0J	RESISTOR	RK 1/10W 2.2K	
	R 941	RK273JA0J	RESISTOR	RK 1/10W 27K	
	R 943	RK562JA0J	RESISTOR	RK 1/10W 5.6	
	R 951	RK562JA0J	RESISTOR	KD-LX330R	
	R 952	RK102JA0J	RESISTOR	RK 1/10W 1K	
	R 953	RK562JA0J	RESISTOR	RK 1/10W 5.6K	
	R 954	RK103JA0J	RESISTOR	RK 1/10W 10K	
	R 962	RK912JA0J	RESISTOR	RK 1/10W 9.1K	
	R 963	RK472JA0J	RESISTOR	RK 1/10W 4.7K	
	R 970	RK123JA0J	RESISTOR	RK 1/10W 12K	
	R 971	RK393JA0J	RESISTOR	RK 1/10W 39K	
	R 976	RK222JA1J	RESISTOR	RK 1/10W 2.2	
	R 977	RK222JA1J	RESISTOR	RK 1/10W 2.2	
	R 978	RK104JA1J	N.F RESISTOR	RK 1/10W 100	
	R 979	RD102J3CQ	RESISTOR	RD 1/4W 1	
	R 981	RK183JA0J	RESISTOR		
	R 984	RK473JA0J	RESISTOR	RK 1/10W 47K	
	R 985	RK472JA0J	N.F RESISTOR	RK 1/10W 4.7K	
	R 986	RK102JA0J	RESISTOR	RK 1/10W 1K	
	R 987	RK473JA0J	RESISTOR	RK 1/10W 47K	
	R 988	RK332JA0J	RESISTOR	RK 1/10W 3.3K	
	S 651	000392900-T	SWITCH	SW MPU12270MLB1	
	S 652	000392900-T	SWITCH	SW MPU12270MLB1	
	S 653	000392900-T	SWITCH	SW MPU12270MLB1	
	TH981	TH103J05J	THERMISTOR	THERMISTOR 10K	
	TU 1	000153580	TUNNER PUCK		
	VR 31	SFR503027	ENCODER		

△	Item	Parts number	Parts name	Remarks	Area
	X 31	000067990	CRYSTAL		
	X 51	000171200-T	CRYSTAL	X'TAL 4.332MHZ	
	X 521	000171590-T	CRYSTAL	X'TAL 16.9344MH	
	X 701	000171600-T	CRYSTAL	X'TAL 12.5MHZ	
	X 702	QAX0401-001	CRYSTAL	X'TAL 32.768KHZ	

■ Electrical parts list (Front board)

Block No. 02

△	Item	Parts number	Parts name	Remarks	Area
	C 601	CY475316J	CAPACITOR	CY 4.7 UF	
	C 602	CY104423J	CAPACITOR	CY 0.1 UF	
	C 603	CY104423J	CAPACITOR	CY 0.1 UF	
	C 604	CY102623J	CAPACITOR	CY 0.001 UF	
	C 605	CY475316J	CAPACITOR	CY 4.7 UF	
	C 606	CY104423J	CAPACITOR	CY 0.1 UF	
	C 607	CY104423J	CAPACITOR	CY 0.1 UF	
	C 608	CY102623J	CAPACITOR	KD-LX110R	
	C 608	CY104423J	CAPACITOR	KD-LX330R	
	C 609	CZ1016D2J	CAPACITOR	KD-LX330R	
	C 610	CY475316J	CAPACITOR	KD-LX330R	
	C 611	CY475316J	CAPACITOR	CY 4.7 UF	
	C 612	CQ393628J	CAPACITOR	CQ 0.039 UF	
	C 613	CY180J90J	CAPACITOR	CY 18 PF	
	C 614	CY104423J	CAPACITOR	CY 0.1 UF	
	C 615	CY562623J	CAPACITOR	CY 0.0056UF	
	C 616	CY475316J	CAPACITOR	CY 4.7 UF	
	C 623	CY475316J	CAPACITOR	CY 4.7 UF	
	CN601	KZ040170L	CONNECTOR	17P FPC CONNECT	
	CN631	KZ040060L	CONNECTOR	6P FPC CONNECTO	
	D 623	000372400-T	DIODE	LED SML310LT	
	D 624	000372400-T	DIODE	LED SML310LT	
	D 625	UDZS5.1B	ZENER DIODE		
	D 626	DI1SS400L	DIODE		
	D 627	000372390-T	DIODE	LED LT1F67AF	
	D 628	000372400-T	DIODE	LED SML310LT	
	D 629	000372400-T	DIODE	LED SML310LT	
	D 630	000372400-T	DIODE	LED SML310LT	
	D 631	CL-190UB-X-X	DIODE	LED CL-190UB-X	
	D 632	000372400-T	DIODE	LED SML310LT	
	D 633	000372400-T	DIODE	LED SML310LT	
	D 634	000372400-T	DIODE	LED SML310LT	
	D 635	000372400-T	DIODE	LED SML310LT	
	D 636	000372400-T	DIODE	LED SML310LT	
	D 637	000372410-T	DIODE	LED CL-190SD-X	
	D 638	000372410-T	DIODE	LED CL-190SD-X	
	D 639	000372410-T	DIODE	LED CL-190SD-X	
	D 640	000372410-T	DIODE	LED CL-190SD-X	
	D 641	000372410-T	DIODE	LED CL-190SD-X	
	D 642	000372410-T	DIODE	LED CL-190SD-X	
	D 643	000372410-T	DIODE	LED CL-190SD-X	
	D 644	000372410-T	DIODE	LED CL-190SD-X	
	D 645	000372410-T	DIODE	LED CL-190SD-X	
	D 646	000372410-T	DIODE	LED CL-190SD-X	
	D 647	000372410-T	DIODE	LED CL-190SD-X	
	D 648	000372410-T	DIODE	LED CL-190SD-X	
	D 650	CL-190UB-X-X	DIODE	LED CL-190UB-X	
	FL611	000282950	CFL	CFL	
	IC601	TA2147F-X	IC		
	IC602	LC75823W	IC	KD-LX110R	
	IC602	LC75811W	I.C(M)	KD-LX330R	
	IC603	RPM6938-SV4	IC	IC RPM6938-V4	
	L 611	LC680J26L	CHOKE COIL	CHOKE COIL 68UH	
	L 612	000125810	COIL	TRANS TR11-B-S	
	L 613	LC100K10J	COIL	CHOKE COIL 10UH	
	PC601	000874550	IC	IC PR-20	
	Q 611	2SD2150/RS-W	POW TRANSISTOR		
	Q 612	2SD2150/RS-W	POW TRANSISTOR		
	Q 691	2SC4081/QR/-X	TRANSISTOR		
	Q 692	2SC4081/QR/-X	TRANSISTOR		
	R 601	RK103JA0J	RESISTOR	RK 1/10W 10K	
	R 602	RK103JA0J	RESISTOR	RK 1/10W 10K	
	R 603	RK103JA0J	RESISTOR	RK 1/10W 10K	

△	Item	Parts number	Parts name	Remarks	Area
	R 604	RK473JA0J	RESISTOR	RK 1/10W 47K	
	R 605	RK103JA0J	RESISTOR	RK 1/10W 10K	
	R 606	RK103JA0J	RESISTOR	RK 1/10W 10K	
	R 607	RK103JA0J	RESISTOR	RK 1/10W 10K	
	R 608	RK473JA0J	RESISTOR	KD-LX110R	
	R 608	RK103JA0J	RESISTOR	KD-LX330R	
	R 609	RK153JA0J	RESISTOR	KD-LX330R	
	R 611	RK472JA0J	RESISTOR	RK 1/10W 4.7K	
	R 612	RK472JA0J	RESISTOR	RK 1/10W 4.7K	
	R 613	RK681JA0J	RESISTOR	RK 1/10W 680	
	R 621	RK271JA0J	RESISTOR	RK 1/10W 270	
	R 622	RK331JA0J	RESISTOR	RK 1/10W 330	
	R 623	RK821JA0J	RESISTOR	RK 1/10W 820	
	R 624	RK821JA0J	RESISTOR	RK 1/10W 820	
	R 625	RK471JA0J	RESISTOR	RK 1/10W 470	
	R 626	RK103JA0J	RESISTOR	RK 1/10W 10K	
	R 627	RK121JA0J	RESISTOR	RK 1/10W 120	
	R 628	RK000JA0J	RESISTOR	RK 1/10W 0	
	R 629	RK471JA0J	RESISTOR	RK 1/10W 470	
	R 630	RK271JA0J	RESISTOR	RK 1/10W 270	
	R 631	RK391JA0J	RESISTOR	RK 1/10W 390	
	R 632	RK221JA0J	RESISTOR	RK 1/10W 220	
	R 633	RK221JA0J	RESISTOR	RK 1/10W 220	
	R 634	RK221JA0J	RESISTOR	RK 1/10W 220	
	R 635	RK221JA0J	RESISTOR	RK 1/10W 220	
	R 636	RK821JA0J	RESISTOR	RK 1/10W 820	
	R 638	RK122JA0J	RESISTOR	RK 1/10W 1.2K	
	R 639	RK182JA0J	RESISTOR	RK 1/10W 1.8K	
	R 640	RK272JA0J	RESISTOR	RK 1/10W 2.7K	
	R 641	RK392JA0J	RESISTOR	RK 1/10W 3.9K	
	R 642	RK821JA0J	RESISTOR	RK 1/10W 820	
	R 643	RK821JA0J	RESISTOR	RK 1/10W 820	
	R 644	RK122JA0J	RESISTOR	RK 1/10W 1.2K	
	R 645	RK182JA0J	RESISTOR	RK 1/10W 1.8K	
	R 646	RK272JA0J	RESISTOR	RK 1/10W 2.7K	
	R 647	RK392JA0J	RESISTOR	RK 1/10W 3.9K	
	R 648	RK271JA0J	RESISTOR	RK 1/10W 270	
	R 649	RK271JA0J	RESISTOR	RK 1/10W 270	
	R 650	RK391JA0J	RESISTOR	RK 1/10W 390	
	R 651	RK221JA0J	RESISTOR	RK 1/10W 220	
	R 652	RK221JA0J	RESISTOR	RK 1/10W 220	
	R 658	RK181JA0J	RESISTOR	RK 1/10W 180	
	R 667	RK104JA0J	RESISTOR	RK 1/10W 100K	
	R 668	RK104JA0J	RESISTOR	RK 1/10W 100K	
	R 671	RK331JA0J	RESISTOR	RK 1/10W 330	
	R 672	RK331JA0J	RESISTOR	RK 1/10W 330	
	R 673	RK332JA0J	RESISTOR	RK 1/10W 3.3K	
	R 674	RK332JA0J	RESISTOR	RK 1/10W 3.3K	
	R 675	RK332JA0J	RESISTOR	RK 1/10W 3.3K	
	R 676	RK181JA0J	RESISTOR	RK 1/10W 180	
	R 691	RK104JA0J	RESISTOR	RK 1/10W 100K	
	R 692	RK393JA0J	RESISTOR	RK 1/10W 39K	
	R 693	RK104JA0J	RESISTOR	RK 1/10W 100K	
	R 694	RK393JA0J	RESISTOR	RK 1/10W 39K	
	RR637	RK821JA0J	RESISTOR	RK 1/10W 820	
	S 623	000392870-T	SWITCH	TACT SW LS8J2	
	S 624	000392870-T	SWITCH	TACT SW LS8J2	
	S 625	000392910-T	SWITCH	TACT SW	
	S 631	000392870-T	SWITCH	TACT SW LS8J2	
	S 632	000392870-T	SWITCH	TACT SW LS8J2	
	S 633	000392870-T	SWITCH	TACT SW LS8J2	
	S 634	000392870-T	SWITCH	TACT SW LS8J2	
	S 635	000392870-T	SWITCH	TACT SW LS8J2	

■ Electrical parts list

Block No. 02

△	Item	Parts number	Parts name	Remarks	Area
	S 636	000392870-T	SWITCH	TACT SW LS8J2	
	S 637	000392870-T	SWITCH	TACT SW LS8J2	
	S 638	000392870-T	SWITCH	TACT SW LS8J2	
	S 639	000392870-T	SWITCH	TACT SW LS8J2	
	S 640	000392870-T	SWITCH	TACT SW LS8J2	
	S 641	000392870-T	SWITCH	TACT SW LS8J2	
	S 642	000392870-T	SWITCH	TACT SW LS8J2	
	S 643	000392870-T	SWITCH	TACT SW LS8J2	
	VR621	000392860	ENCODER	ENCODER EC12E	